

NOTES:

A- INSTALL ITEM #20 (SCREW) IN ASSEMBLY

B- SEE OPERATING MANUAL IRB-180 FOR LUBRICATION INSTRUCTION

C- 2-1/2, 3-1/2, & 4" REQ'D SOC. HD. ON G.E. ONLY

E- REQ'D ON 22 & 42 ONLY

F- NUT TO BE TORQUED TO:

2-1/2---60 LB.FT.

3-1/2---110 LB.FT.

4---190 LB.FT.

5---250 LB.FT.

G- FOR SIGHT GLASS UNITS ONLY. USE WASHER OUTSIDE OF GEARBOX. USE RED LITTE ON THE THREADS.

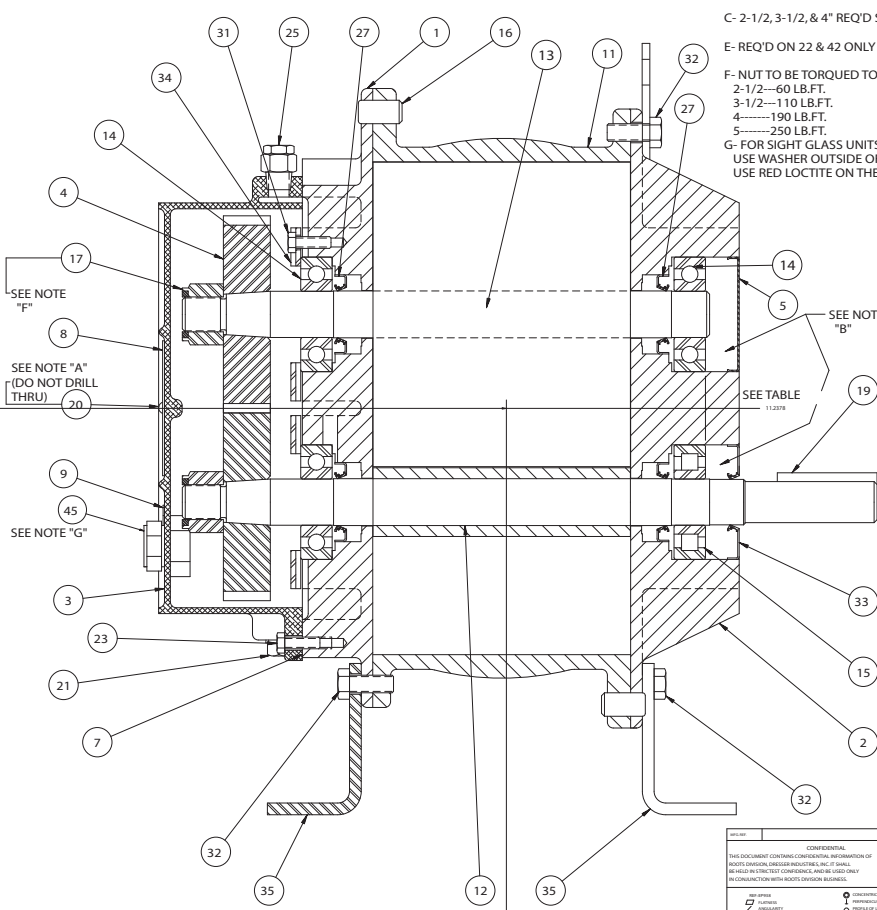

SIZE	"X" .005
5	0.831
4	0.731
3-1/2	0.585
2-1/2	0.427

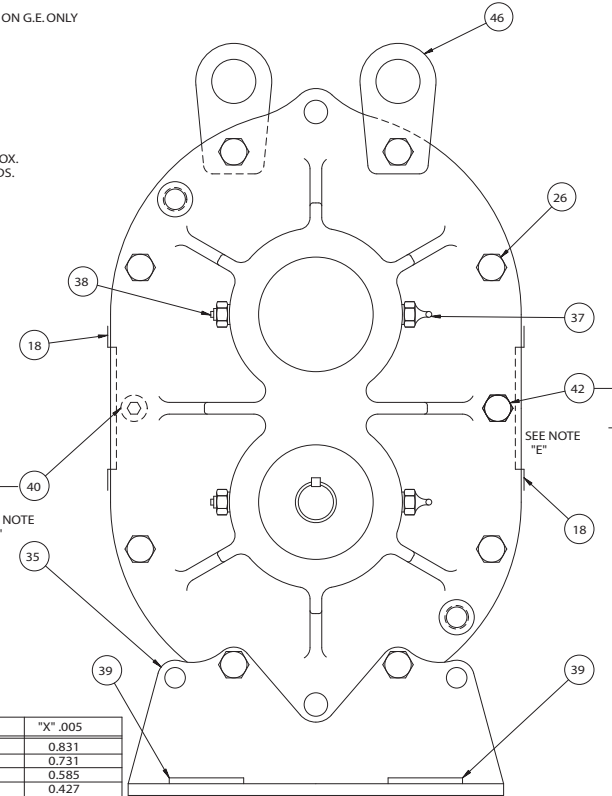

SEE NOTE "F"

SEE NOTE "A" (DO NOT DRILL THRU)

SEE NOTE "G"

SEE NOTE "B"

SEE TABLE 11.2378

SEE NOTE "C"

SEE NOTE "E"

CONFIDENTIAL
 THIS DOCUMENT CONTAINS CONFIDENTIAL INFORMATION OF
 ROOTS DESIGN, DRESSER ROOTS, INC. IT SHALL
 BE HELD IN STRICTLY CONFIDENTIAL MANNER AND USED
 IN CONNECTION WITH ROOTS DIVISION BUSINESS.

APPROVED
 CALIBRATED
 DIMENSIONED
 FINISHED
 INSPECTED
 REVIEWED

IDENTIFIED
 IDENTIFIED
 IDENTIFIED
 IDENTIFIED
 IDENTIFIED

REV	DATE	BY	CHKD	APP'D	DESCRIPTION
1					ADD LIFTING LUGS (ITEM #6)
2					ADD ITEM #1 FOR SIGHT GLASS UNITS
3					GRADED ITEM #1
4					REVISED FOR ECU
5					INCREASE SIZE OF NUT TORQUE
6					ITEM #20 NOT TO BE DRILL
7					LUBRICATION NOTE & REVISED
8					REWORKING
9					ITEM #42 MODIFIED
10					NEW PART NUMBER

DO NOT SCALE FOR DIMENSIONS

SECTIONAL ASSEMBLY
 2-1/2 THRU 5" U-BAL BLOWERS
 TAPER ROSE GEARS

DRESSER
 Roots
 DRESSER ROOTS, DRESSER, INC.
 INDUSTRIAL, TX

64720023

REV J

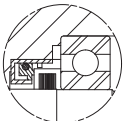

VIEW "X"

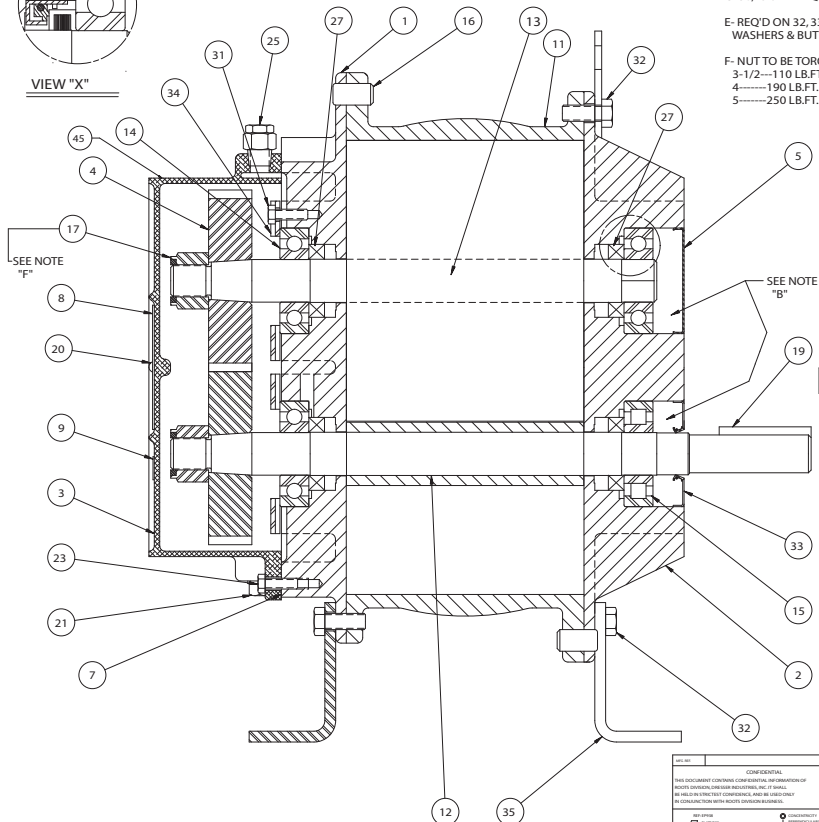

NOTES:

- A- USE LOCKTITE #2 (30515) BETWEEN HEADPLATE AND CYLINDER JOINTS.
- B- SEE OPERATING MANUAL IRB-180 FOR GAS BLOWERS FOR LUBRICATION INSTRUCTION.
- C- 36,45 & 47 REQ'D SOC.HD.ON G.E.ONLY

E- REQ'D ON 32,33 & 42 URAI-G ONLY-SEALING WASHERS & BUTTONHEAD CAPSCREWS.

- F- NUT TO BE TORQUED TO:
- 3-1/2---110 LB.FT.
 - 4-----190 LB.FT.
 - 5-----250 LB.FT.

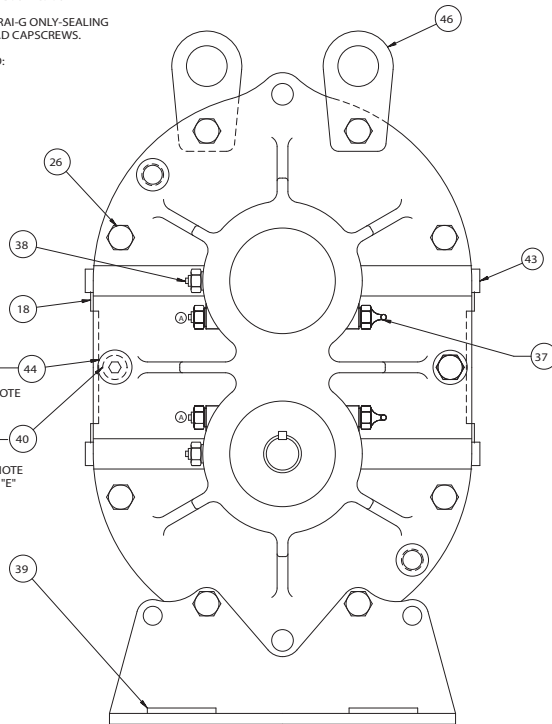

REV. NO.		DATE		BY		CHKD.		APP'D.		H																																																																																																																																																																																																																																												
CONFIDENTIAL																																																																																																																																																																																																																																																						
THIS DOCUMENT CONTAINS CONFIDENTIAL INFORMATION OF DRESSER INDUSTRIAL CORP. OR DRESSER INDUSTRIES, INC. IT IS THE PROPERTY OF DRESSER INDUSTRIAL CORP. OR DRESSER INDUSTRIES, INC. AND IS TO BE KEPT CONFIDENTIAL AND NOT REPRODUCED OR TRANSMITTED IN ANY FORM OR BY ANY MEANS, ELECTRONIC OR MECHANICAL, INCLUDING PHOTOCOPYING, RECORDING, OR BY ANY INFORMATION STORAGE AND RETRIEVAL SYSTEM, WITHOUT THE WRITTEN PERMISSION OF DRESSER INDUSTRIAL CORP. OR DRESSER INDUSTRIES, INC.																																																																																																																																																																																																																																																						
<table border="1" style="width: 100%;"> <tr> <td>REV. NO.</td> <td>DATE</td> <td>BY</td> <td>CHKD.</td> <td>APP'D.</td> </tr> <tr> <td>1</td> <td>01/01/00</td> <td>JK</td> <td>JK</td> <td>JK</td> </tr> <tr> <td>2</td> <td>01/01/00</td> <td>JK</td> <td>JK</td> <td>JK</td> </tr> <tr> <td>3</td> <td>01/01/00</td> <td>JK</td> <td>JK</td> <td>JK</td> </tr> <tr> <td>4</td> <td>01/01/00</td> <td>JK</td> <td>JK</td> <td>JK</td> </tr> <tr> <td>5</td> <td>01/01/00</td> <td>JK</td> <td>JK</td> <td>JK</td> </tr> <tr> <td>6</td> <td>01/01/00</td> <td>JK</td> <td>JK</td> <td>JK</td> </tr> <tr> <td>7</td> <td>01/01/00</td> <td>JK</td> <td>JK</td> <td>JK</td> </tr> <tr> <td>8</td> <td>01/01/00</td> <td>JK</td> <td>JK</td> <td>JK</td> </tr> <tr> <td>9</td> <td>01/01/00</td> <td>JK</td> <td>JK</td> <td>JK</td> </tr> <tr> <td>10</td> <td>01/01/00</td> <td>JK</td> <td>JK</td> <td>JK</td> </tr> <tr> <td>11</td> <td>01/01/00</td> <td>JK</td> <td>JK</td> <td>JK</td> </tr> <tr> <td>12</td> <td>01/01/00</td> <td>JK</td> <td>JK</td> <td>JK</td> </tr> <tr> <td>13</td> <td>01/01/00</td> <td>JK</td> <td>JK</td> <td>JK</td> </tr> <tr> <td>14</td> <td>01/01/00</td> <td>JK</td> <td>JK</td> <td>JK</td> </tr> <tr> <td>15</td> <td>01/01/00</td> <td>JK</td> <td>JK</td> <td>JK</td> </tr> <tr> <td>16</td> <td>01/01/00</td> <td>JK</td> <td>JK</td> <td>JK</td> </tr> <tr> <td>17</td> <td>01/01/00</td> <td>JK</td> <td>JK</td> <td>JK</td> </tr> <tr> <td>18</td> <td>01/01/00</td> <td>JK</td> <td>JK</td> <td>JK</td> </tr> <tr> <td>19</td> <td>01/01/00</td> <td>JK</td> <td>JK</td> <td>JK</td> </tr> <tr> <td>20</td> <td>01/01/00</td> <td>JK</td> <td>JK</td> <td>JK</td> </tr> <tr> <td>21</td> <td>01/01/00</td> <td>JK</td> <td>JK</td> <td>JK</td> </tr> <tr> <td>22</td> <td>01/01/00</td> <td>JK</td> <td>JK</td> <td>JK</td> </tr> <tr> <td>23</td> <td>01/01/00</td> <td>JK</td> <td>JK</td> <td>JK</td> </tr> <tr> <td>24</td> <td>01/01/00</td> <td>JK</td> <td>JK</td> <td>JK</td> </tr> <tr> <td>25</td> <td>01/01/00</td> <td>JK</td> <td>JK</td> <td>JK</td> </tr> <tr> <td>26</td> <td>01/01/00</td> <td>JK</td> <td>JK</td> <td>JK</td> </tr> <tr> <td>27</td> <td>01/01/00</td> <td>JK</td> <td>JK</td> <td>JK</td> </tr> <tr> <td>28</td> <td>01/01/00</td> <td>JK</td> <td>JK</td> <td>JK</td> </tr> <tr> <td>29</td> <td>01/01/00</td> <td>JK</td> <td>JK</td> <td>JK</td> </tr> <tr> <td>30</td> <td>01/01/00</td> <td>JK</td> <td>JK</td> <td>JK</td> </tr> <tr> <td>31</td> <td>01/01/00</td> <td>JK</td> <td>JK</td> <td>JK</td> </tr> <tr> <td>32</td> <td>01/01/00</td> <td>JK</td> <td>JK</td> <td>JK</td> </tr> <tr> <td>33</td> <td>01/01/00</td> <td>JK</td> <td>JK</td> <td>JK</td> </tr> <tr> <td>34</td> <td>01/01/00</td> <td>JK</td> <td>JK</td> <td>JK</td> </tr> <tr> <td>35</td> <td>01/01/00</td> <td>JK</td> <td>JK</td> <td>JK</td> </tr> <tr> <td>36</td> <td>01/01/00</td> <td>JK</td> <td>JK</td> <td>JK</td> </tr> <tr> <td>37</td> <td>01/01/00</td> <td>JK</td> <td>JK</td> <td>JK</td> </tr> <tr> <td>38</td> <td>01/01/00</td> <td>JK</td> <td>JK</td> <td>JK</td> </tr> <tr> <td>39</td> <td>01/01/00</td> <td>JK</td> <td>JK</td> <td>JK</td> </tr> <tr> <td>40</td> <td>01/01/00</td> <td>JK</td> <td>JK</td> <td>JK</td> </tr> <tr> <td>41</td> <td>01/01/00</td> <td>JK</td> <td>JK</td> <td>JK</td> </tr> <tr> <td>42</td> <td>01/01/00</td> <td>JK</td> <td>JK</td> <td>JK</td> </tr> <tr> <td>43</td> <td>01/01/00</td> <td>JK</td> <td>JK</td> <td>JK</td> </tr> <tr> <td>44</td> <td>01/01/00</td> <td>JK</td> <td>JK</td> <td>JK</td> </tr> <tr> <td>45</td> <td>01/01/00</td> <td>JK</td> <td>JK</td> <td>JK</td> </tr> <tr> <td>46</td> <td>01/01/00</td> <td>JK</td> <td>JK</td> <td>JK</td> </tr> </table>												REV. NO.	DATE	BY	CHKD.	APP'D.	1	01/01/00	JK	JK	JK	2	01/01/00	JK	JK	JK	3	01/01/00	JK	JK	JK	4	01/01/00	JK	JK	JK	5	01/01/00	JK	JK	JK	6	01/01/00	JK	JK	JK	7	01/01/00	JK	JK	JK	8	01/01/00	JK	JK	JK	9	01/01/00	JK	JK	JK	10	01/01/00	JK	JK	JK	11	01/01/00	JK	JK	JK	12	01/01/00	JK	JK	JK	13	01/01/00	JK	JK	JK	14	01/01/00	JK	JK	JK	15	01/01/00	JK	JK	JK	16	01/01/00	JK	JK	JK	17	01/01/00	JK	JK	JK	18	01/01/00	JK	JK	JK	19	01/01/00	JK	JK	JK	20	01/01/00	JK	JK	JK	21	01/01/00	JK	JK	JK	22	01/01/00	JK	JK	JK	23	01/01/00	JK	JK	JK	24	01/01/00	JK	JK	JK	25	01/01/00	JK	JK	JK	26	01/01/00	JK	JK	JK	27	01/01/00	JK	JK	JK	28	01/01/00	JK	JK	JK	29	01/01/00	JK	JK	JK	30	01/01/00	JK	JK	JK	31	01/01/00	JK	JK	JK	32	01/01/00	JK	JK	JK	33	01/01/00	JK	JK	JK	34	01/01/00	JK	JK	JK	35	01/01/00	JK	JK	JK	36	01/01/00	JK	JK	JK	37	01/01/00	JK	JK	JK	38	01/01/00	JK	JK	JK	39	01/01/00	JK	JK	JK	40	01/01/00	JK	JK	JK	41	01/01/00	JK	JK	JK	42	01/01/00	JK	JK	JK	43	01/01/00	JK	JK	JK	44	01/01/00	JK	JK	JK	45	01/01/00	JK	JK	JK	46	01/01/00	JK	JK	JK
REV. NO.	DATE	BY	CHKD.	APP'D.																																																																																																																																																																																																																																																		
1	01/01/00	JK	JK	JK																																																																																																																																																																																																																																																		
2	01/01/00	JK	JK	JK																																																																																																																																																																																																																																																		
3	01/01/00	JK	JK	JK																																																																																																																																																																																																																																																		
4	01/01/00	JK	JK	JK																																																																																																																																																																																																																																																		
5	01/01/00	JK	JK	JK																																																																																																																																																																																																																																																		
6	01/01/00	JK	JK	JK																																																																																																																																																																																																																																																		
7	01/01/00	JK	JK	JK																																																																																																																																																																																																																																																		
8	01/01/00	JK	JK	JK																																																																																																																																																																																																																																																		
9	01/01/00	JK	JK	JK																																																																																																																																																																																																																																																		
10	01/01/00	JK	JK	JK																																																																																																																																																																																																																																																		
11	01/01/00	JK	JK	JK																																																																																																																																																																																																																																																		
12	01/01/00	JK	JK	JK																																																																																																																																																																																																																																																		
13	01/01/00	JK	JK	JK																																																																																																																																																																																																																																																		
14	01/01/00	JK	JK	JK																																																																																																																																																																																																																																																		
15	01/01/00	JK	JK	JK																																																																																																																																																																																																																																																		
16	01/01/00	JK	JK	JK																																																																																																																																																																																																																																																		
17	01/01/00	JK	JK	JK																																																																																																																																																																																																																																																		
18	01/01/00	JK	JK	JK																																																																																																																																																																																																																																																		
19	01/01/00	JK	JK	JK																																																																																																																																																																																																																																																		
20	01/01/00	JK	JK	JK																																																																																																																																																																																																																																																		
21	01/01/00	JK	JK	JK																																																																																																																																																																																																																																																		
22	01/01/00	JK	JK	JK																																																																																																																																																																																																																																																		
23	01/01/00	JK	JK	JK																																																																																																																																																																																																																																																		
24	01/01/00	JK	JK	JK																																																																																																																																																																																																																																																		
25	01/01/00	JK	JK	JK																																																																																																																																																																																																																																																		
26	01/01/00	JK	JK	JK																																																																																																																																																																																																																																																		
27	01/01/00	JK	JK	JK																																																																																																																																																																																																																																																		
28	01/01/00	JK	JK	JK																																																																																																																																																																																																																																																		
29	01/01/00	JK	JK	JK																																																																																																																																																																																																																																																		
30	01/01/00	JK	JK	JK																																																																																																																																																																																																																																																		
31	01/01/00	JK	JK	JK																																																																																																																																																																																																																																																		
32	01/01/00	JK	JK	JK																																																																																																																																																																																																																																																		
33	01/01/00	JK	JK	JK																																																																																																																																																																																																																																																		
34	01/01/00	JK	JK	JK																																																																																																																																																																																																																																																		
35	01/01/00	JK	JK	JK																																																																																																																																																																																																																																																		
36	01/01/00	JK	JK	JK																																																																																																																																																																																																																																																		
37	01/01/00	JK	JK	JK																																																																																																																																																																																																																																																		
38	01/01/00	JK	JK	JK																																																																																																																																																																																																																																																		
39	01/01/00	JK	JK	JK																																																																																																																																																																																																																																																		
40	01/01/00	JK	JK	JK																																																																																																																																																																																																																																																		
41	01/01/00	JK	JK	JK																																																																																																																																																																																																																																																		
42	01/01/00	JK	JK	JK																																																																																																																																																																																																																																																		
43	01/01/00	JK	JK	JK																																																																																																																																																																																																																																																		
44	01/01/00	JK	JK	JK																																																																																																																																																																																																																																																		
45	01/01/00	JK	JK	JK																																																																																																																																																																																																																																																		
46	01/01/00	JK	JK	JK																																																																																																																																																																																																																																																		
<p>SECTIONAL ASSEMBLY 3-1/2 THRU 5" U-RAI GAS BLOWERS</p> <p>DRESSER Floora DRESSER-FLOORA, DRESSER INC., HOUSTON, TX</p> <p>T30099023 REV D</p>																																																																																																																																																																																																																																																						

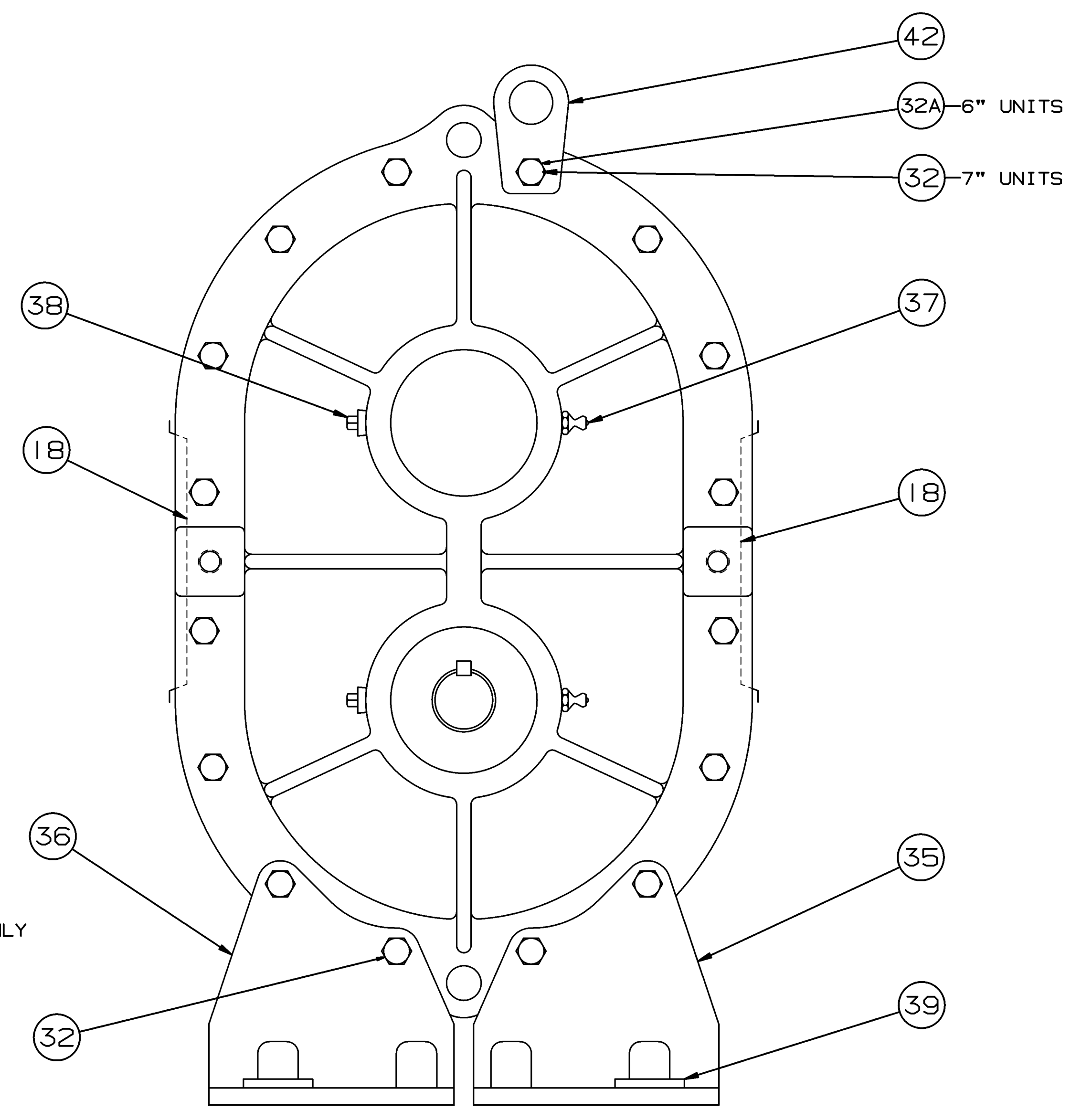
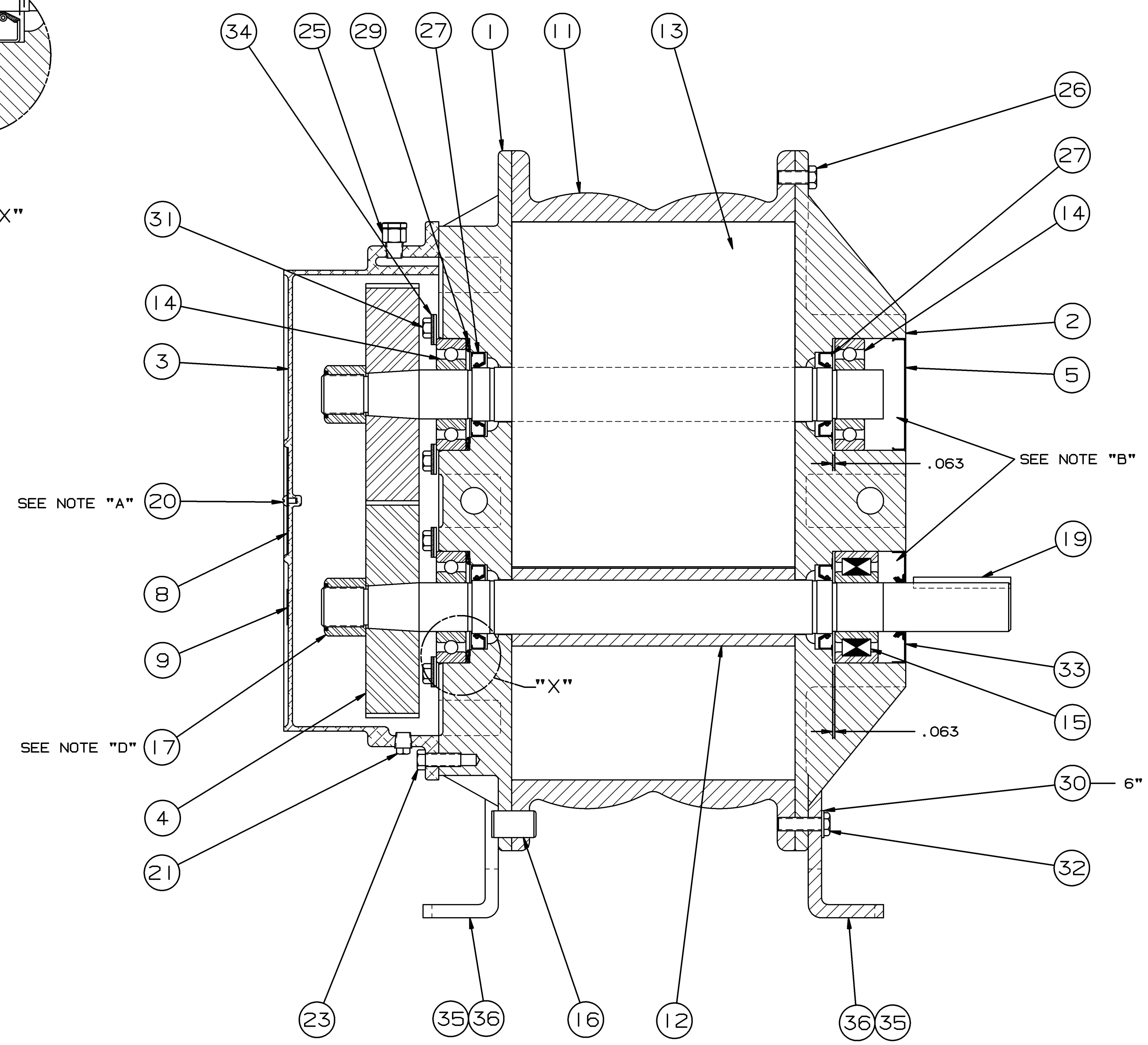
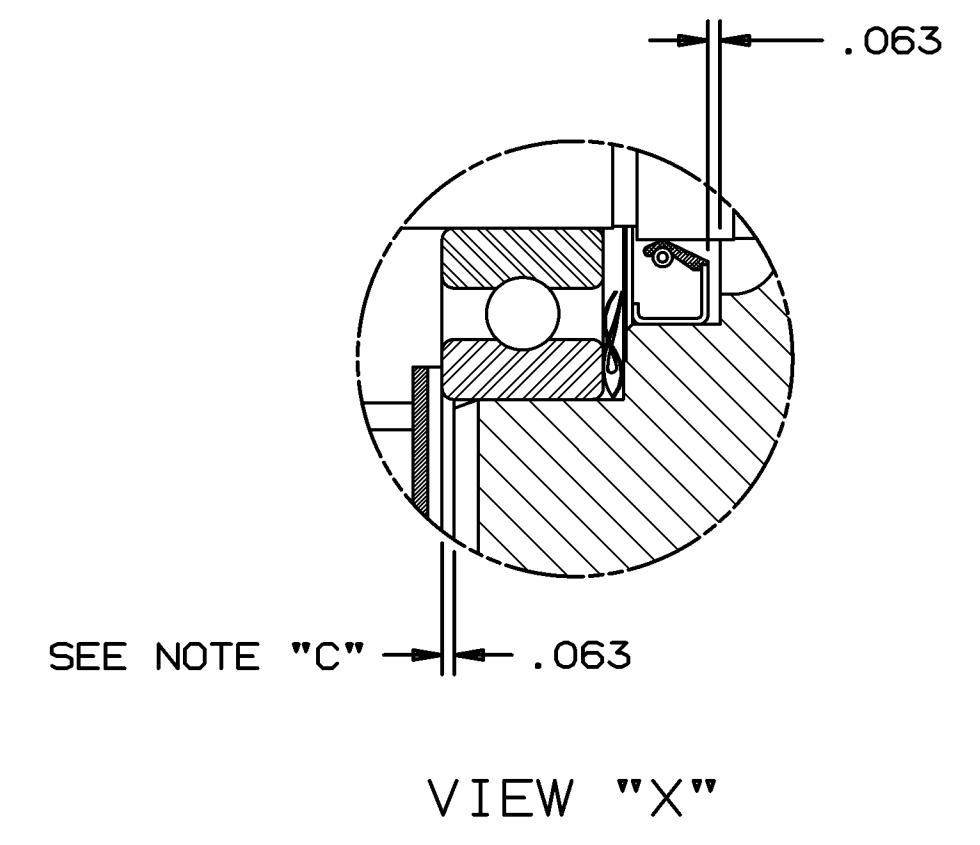

- NOTES**
- A INSTALL ITEM #20 (SCREW) IN ASSEMBLY
 - B SEE OPERATING MANUAL IRB-103 FOR LUBRICATION INSTRUCTION
 - C INSTALL BEARINGS AS SHOWN BEFORE SETTING END CLEARANCE
 - D NUT TO BE TORQUED TO:
6"---400 LB. FT.
7"---550 LB. FT.

- (E) 3577V
- (D) 3389V
- (C) 3339V

MFG. REF.	62600023									DATE	DO NOT SCALE FOR DIMENSIONS ALL DIMENSIONS SHOWN IN BRACKETS () ARE MILLIMETERS	ORDER No.	55-1242-2	
CONFIDENTIAL														
THIS DOCUMENT CONTAINS CONFIDENTIAL INFORMATION OF ROOTS DIVISION, DRESSER INDUSTRIES, INC. IT SHALL BE HELD IN STRICTEST CONFIDENCE, AND BE USED ONLY IN CONJUNCTION WITH ROOTS DIVISION BUSINESS.														
REF: EP938	CONCENTRICITY													
FLATNESS	PERPENDICULARITY													
ANGULARITY	PROFILE OF LINE													
PARALLELISM	PROFILE OF A SURFACE													
TRUE POSITION	DIAMETER													
STRAIGHTNESS	FINISH IN MICRO INCHES													
H	ADDED ITEM 32A	AKP	12/12/05	7631V							SCALE 6" = 1'-0"			
G	REMOVED ITEM 44	AJK	6/21/05	7527V	AGP						CAD FILE / DIRECTORY			
F	ADDED ITEM 44	RDR	3/4/05	7419V							64792A23			
REVISIONS														
	BY	DATE	CHANGE NOTICE	CHKD.	APP									
					XASR									
											DRESSER ROOTS		ROOTS DIVISION DRESSER EQUIPMENT GROUP A HALLIBURTON COMPANY HOUSTON, TX USA	
											DIMENSIONAL TOLERANCES UNLESS OTHERWISE SPECIFIED		REV H	
											TWO PLACE DECIMAL (1:20)---+0.015		64792023	
											THREE PLACE DECIMAL (1:200)---+0.006		FRACTIONAL---+1/64	