

ROOTS Blowers & Vacuum Pumps **DRESSER**

RBTM RANGE

POSITIVE DISPLACEMENT AIR BLOWERS

FOR BULK TRANSPORT VEHICLES

TYPE 68 RBTM

User Benefits

- Vehicle loads are discharged with low noise levels and engine speeds to minimise dust nuisance (see performance graph).
- A hydraulic pump with a compact drive arrangement is available for vehicles having a single power take-off aperture or a limited power gearbox, and also for direct coupled power packs.
- The blower can be operated with a longitudinal inclination of up to 10° without risk of oil starvation: this is of particular importance when the vehicle is not standing on level ground.
- There are no wear tips or inserts on the impellers which need to be bedded in after installation, and which might subsequently become detached or damaged causing the vehicle load to become contaminated by foreign matter. Air gaps at each end of the cylinder ensure that there can be no contamination by oil or oil vapours.
- Centre timing permits operation in either direction – vertical or horizontal air flow.
- Suitable for combined pressure and exhauster applications with vacuum up to 475 mbar.
- All machines are given a works overload test from cold to prove their reliability.

Specification

Casing: The cylinder and headplates are manufactured from cast iron.

Impellers and Shafts: The impellers and shafts are of one-piece construction, with axial location and centre timing.

Gears: The straight spur timing gears are taper mounted onto the shafts, and operate in a totally enclosed gearcase.

Bearings: The bearings are of generous proportions to give long operational life. Grease lubricated angular contact locating bearings are used at the drive end. Roller bearings at the gear end are splash lubricated from the gears.

Lubrication: A patented gear trough controls the lubricating oil system, allowing the blower to operate at maximum speeds without the need for an oil pump. Oil throwers are fitted behind each gear end bearing: these do not require maintenance.

Air Gaps: The blower is constructed with an air gap at each end, between bearing and cylinder, to ensure that the delivered air cannot become contaminated by oil or oil vapours.

Timing: When a standard machine is to provide a horizontal airflow, the top shaft is extended for the drive. If the machine is mounted for vertical airflow, the drive shaft is on the right. The position of the shaft is given when looking at the machine from the drive shaft end. Centre timing enables the blower to operate in either direction. If the machine is required with a bottom or left hand shaft extended, all that needs to be done is to turn the gearcase and trough 180°. Detailed instructions are given in the installation and operating instruction folder.

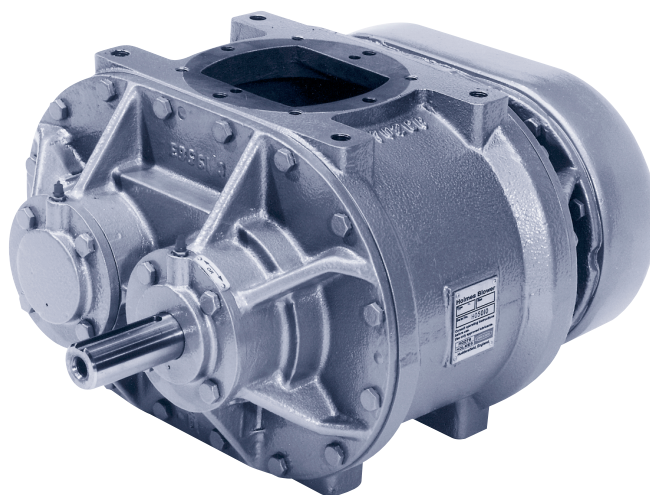

Tachometer Offtake: A mechanically driven tachometer offtake is available as an option on the gearcase cover. Whilst this is normally driven from the bottom shaft on a standard machine, it can easily be changed to the alternative top position.

Blower Protection Devices

Blowers should be protected against differential pressures in excess of those for which they are designed. The following equipment is recommended to give the required protection.

Relief Valve: A pressure relief valve is essential to protect the blower against over pressure in the event of line blockage. The relief valve must be selected, set and maintained so that it will pass the full volume of air delivered by the blower, without the pressure at the outlet exceeding that shown on the performance graph.

Vacuum Indicator: A visual vacuum indicator 350 mm wg (15 in) maximum vacuum should be placed between the air filter and the blower inlet to give warning when the filter requires cleaning. If the filter is not kept clean the blower may seize due to high rotor temperature caused by air starvation. This can result in serious damage to the blower.

Inlet Filter: An inlet filter of adequate capacity should be fitted to the intake of the blower. A filter can, with advantage, be combined with a silencer.

Discharge Silencer: A discharge silencer is beneficial for all applications, and particularly when long lengths of flexible hose are used, as for example, with tractor mounted blowers for articulate units.

Non-Return Valve: It is essential to fit a non-return valve. On pneumatic cargo discharge systems reverse air flow could cause material to be forced back into the blower resulting in serious damage.

All dimensions in millimetres.
Standard machine drawing shown for illustration purposes only.

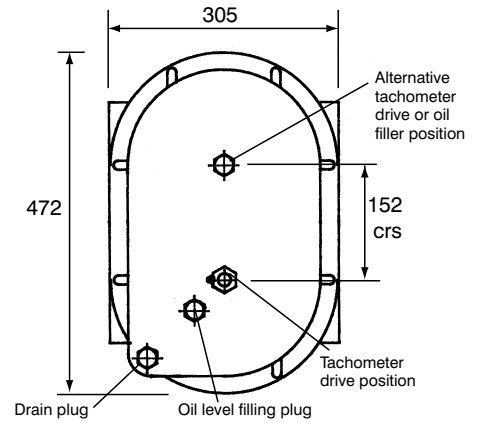
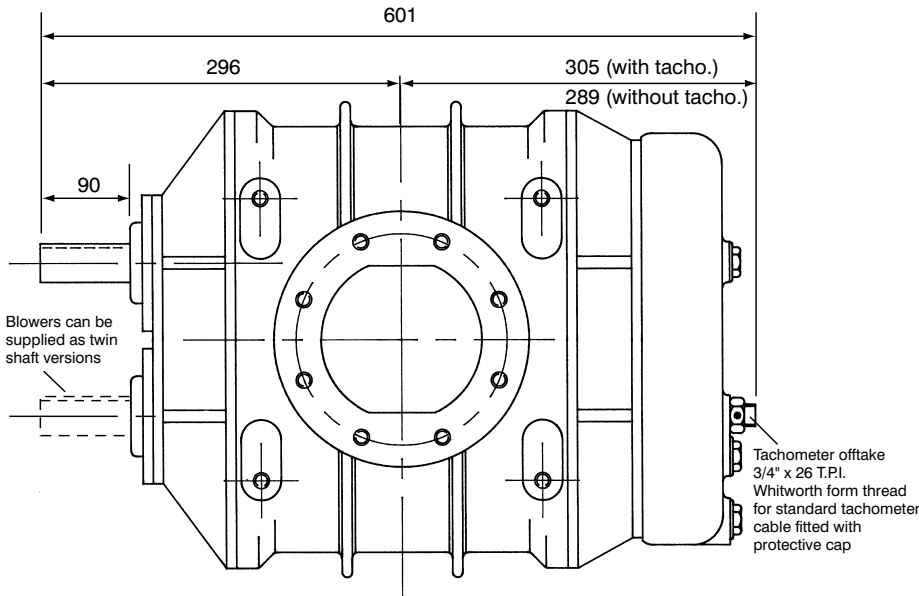

Bare shaft blower with tipper pump (CS P30)

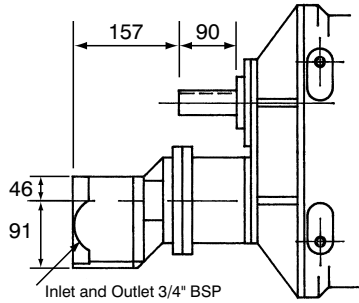

N.B. Other types of pumps with compatible flange/shaft dimensions may be fitted e.g. Volvo F1 Series.

Hydraulic drive

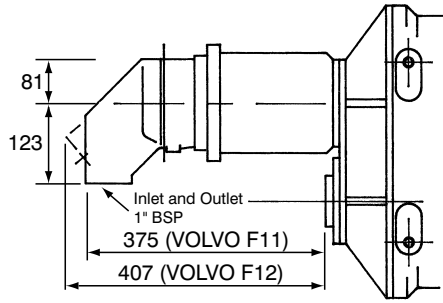

N.B. Volvo tipper pump can be fitted/supplied in combination with Volvo hydraulic drive motors.

Flange

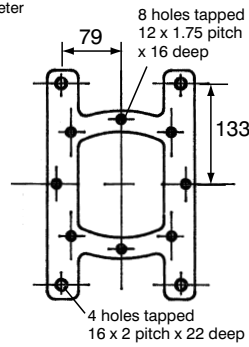

Drive Shaft

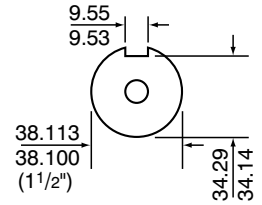

Weight
Net Weight = 120 kg

Type of Drive

The type RBTM machines are suitable for direct drive from the power take-off; belt drive; independent drive from a petrol or diesel powerpack or by a hydraulic pump and motor. A vee-belt drive directly onto the blower shaft cannot be used if the blower is fitted with a speed increasing gearbox or a hydraulic pump.

Blower Performance

The graph opposite and the table below show blower performance. The RBTM range can also operate as exhausters at vacuums up to 475 mbar or combinations of pressure and vacuum. Please refer to the applications department at the address below for further information on vacuum duties.

Minimum Recommended Speed (rpm)	1000	1450
Maximum Relief Valve Pressure (mbar)	1035	1240

The relief valve should be selected, set and maintained to pass all the volume delivered without the pressure at the outlet of the blower exceeding the above maximum pressure when the minimum recommended speed is that shown in the above table.

Caution: The bhp remains constant for any given impeller speed and outlet pressure. When selecting power take-off equipment, relate the bhp to the blower input shaft speed if a speed increasing gearbox is used. The torque increases in direct proportion to the blower gearbox ratio.

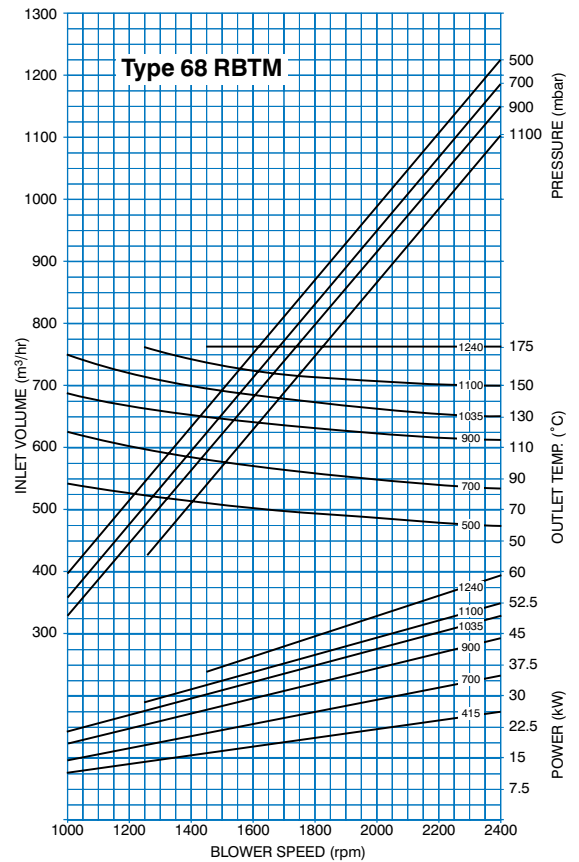

Following the Company's policy of constant development, we reserve the right to alter any detail specified or illustrated in this data sheet without notice and without incurring any obligation to provide such modifications on machines previously delivered. The inclusion of any item of equipment does not imply that it is a standard component on the product featured.



ROOTS Blowers & Vacuum Pumps

Gillibrands Rd, East Gillibrands Estate, Skelmersdale, Lancashire WN8 9TU England
Tel: +44 (0) 1695 52600 Fax: +44 (0) 1695 52610 Email: roots.europe@dresser.com

Website: www.dresser.com/rootsblowers