

BLOWER	A	B	C WITH TACHO.	C WITHOUT TACHO.	NET WEIGHT Kg
68 RBTM	601	296	305	289	120
610RBTM	651	321	330	312	143
613 RBTM	727	359	368	350	165

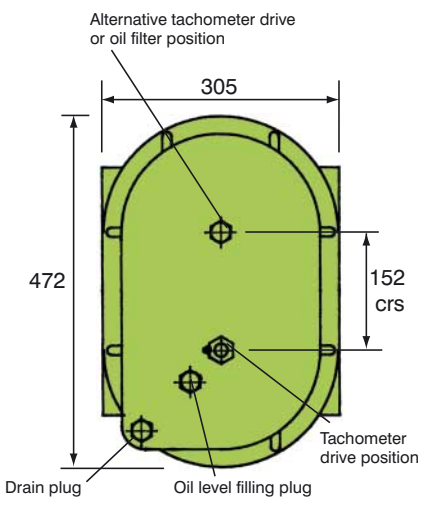

FLANGES

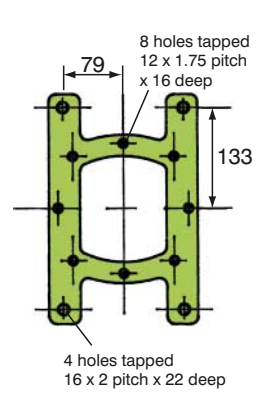

68 RBTM

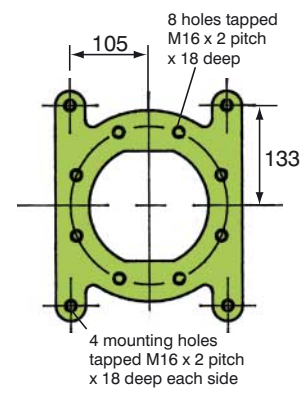

610 RBTM

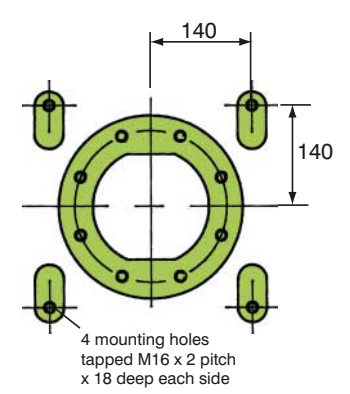

613 RBTM

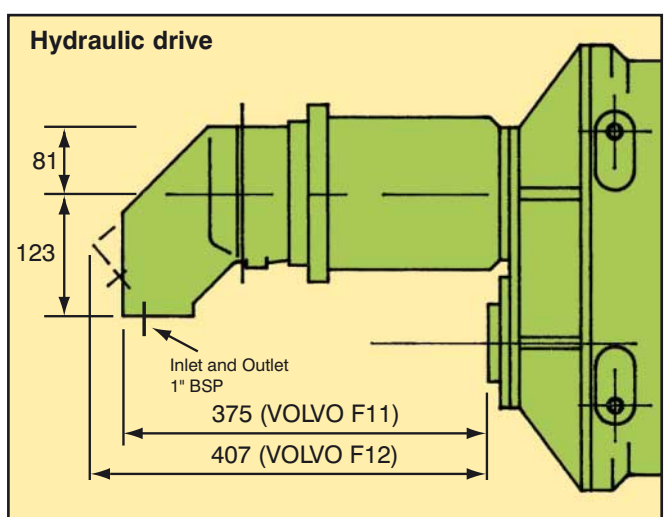
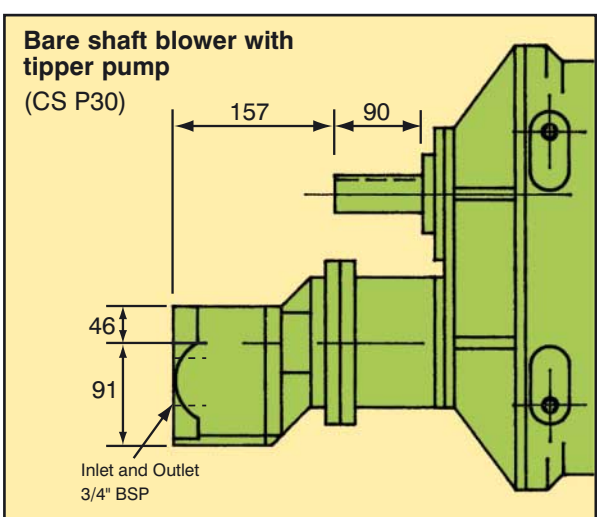

N.B. Other types of pumps with compatible flange/shaft dimensions may be fitted e.g. Volvo F1 Series

N.B. Volvo tipper pump can be fitted/supplied in combination with Volvo hydraulic drive motors.