

EasyAir® X2 Factory Blower Package System

Installation, Operation & Maintenance



Contents

| | | | |
|--|-----|--|-------|
| Machine Warning Signs..... | 2 | Installation & Start-Up..... | 6-9 |
| Safety Precautions..... | 3 | Location Requirements..... | 7 |
| Long Term Storage..... | 3 | Lifting and Moving..... | 7-8 |
| Owner Responsibility..... | 4 | Piping Configuration/Discharge Check Valve Installation..... | 10 |
| Operating Limitations..... | 4 | Maintenance & Lubrication..... | 11-19 |
| Description..... | 5 | Vacuum Package..... | 20 |
| Protection Devices & Accessories..... | 6 | Package Orientation..... | 21 |
| Door Removal/Installation Procedure..... | 6-7 | Wiring Diagram..... | 22 |

Do These Things To Get The Most From Your ROOTS™ Blower

- ❑ Check shipments for damage in transit. After filing claim with carrier, notify Roots Sales Office.
- ❑ Unpack Shipment carefully and check , contents against Packing List. Notify Roots if a shortage appears.
- ❑ Store in a clean, dry location until ready for installation. Lift by methods discussed under INSTALLATION to avoid straining or distorting the equipment. Keep covers on all openings. Protect against weather, and corrosion if outdoor storage is necessary.
- ❑ Read the manual and plan the complete installation. If supervision by a Roots Service Engineer is needed, contact the Roots Sales Office at least two weeks in advance and confirm by your purchase order.
- ❑ Provide for adequate safeguards against accidents to persons, working on or near the equipment during both installation and operation. See SAFETY PRECAUTIONS.
- ❑ Install all equipment as instructed. Foundation design must be adequate and piping carefully done to provide trouble free operation. Use recommended protection devices and accessories.
- ❑ Make sure both driving and driven equipment is correctly lubricated before start-up. See MAINTENANCE AND LUBRICATION.
- ❑ Complete start-up check list on pg 8. Run equipment briefly to check for obvious faults, and make corrections. Then make a trial run under normal operating conditions.
- ❑ In the event of trouble during installation or operation of a new unit, do not attempt repairs. Notify nearest Roots Sales Office, giving all nameplate information plus an outline of operating conditions and a description of the trouble.
- ❑ Units out of warranty may be repaired or adjusted by the owner. It is recommended that such work be limited to the operations described in this manual. Use of a Roots Authorized Distributor to perform repairs is recommended. Good inspection and maintenance practices should reduce the need for major repair.

NOTE - Information in this manual is correct as of the date of publication. The Manufacturer reserves the right to make design or material change without notice, and without obligation to make similar changes to equipment of prior manufacture.

For your nearest Roots Sales Office call 832-590-2600.

ROOTS® products are sold subject to the current General Terms of Sale, GTS-5001 and Warranty Policy WP-5020-SFP. Copies are available upon request. Contact your local Roots Office or Roots Customer Service Hot Line 1-877-363-ROOT(S) (7668) or direct 832-590-2305.

Machine Warning Signs

Make sure that everyone concerned with operating this machine has fully read and understood this instruction manual, and that they are fully aware of the meanings of the following warning symbols. Some symbols may also be found on relevant parts of the machine.



WARNING! Do not stand on any protruding parts of the unit.



WARNING! Pressurized air can be dangerous. To avoid death or serious personal injury and the risks associated with this type of machine, use safe working procedures. Do not inhale compressed air from the machine, this may also contain gas vapors or solid particles.



WARNING! Ensure machine is fully isolated from mains supply, locked out and the air pressure has been totally relieved before carrying out any maintenance work.



WARNING! Risk of electrical shock. Disconnect from mains supply before removing any covers.



WARNING! Rotating parts. Do not operate without guards in place.



WARNING! Read instruction manual carefully before positioning, operating or making any adjustments.



WARNING! Hot surface. This unit contains surfaces which reach high temperatures during operation.



Ground



WARNING! Risk of accidental start-up. The machine could start automatically in the event of a power cut, reset or when attached as part of an automated system.

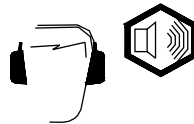

WARNING! The unit produces a high sound level during operation. Ear protection should be worn if doors are opened for observation.



WARNING! Pressurized component or system.

Safety Precautions



CAUTION:

The machine is delivered without lubrication. Lubrication must be added before starting up. See page 10.

Follow these precautions in addition to any other local safety regulations when installing, maintaining or operating the machine:

METHODS OF WORKING

- Use proper care and good procedures in handling, lifting, installing, operating and maintaining the equipment.
- Electrical work must only be carried out by suitably qualified and authorized personnel.
- Make sure that the electrical supply is of the specified voltage and has adequate fuse protection.
- Isolate the electrical supply and release all air pressure before attempting to carry out work on the machine.
- The machine is not intended for use as a workstation.
- Lubrication must be handled, contained and disposed of in a safe and suitable manner.
- Provide adequate safeguards against accidents for persons working in, on or near the machine during installation and operation.
- Do not direct high-pressure air at any part of the body.
- Do not stack units.

HAZARDS

- The blower casing and associated piping and accessories may become hot enough to cause major skin burns on contact.
- Do not reach into any part of the enclosure or blower when it is operating or liable to accidental starting. Internal and external rotating parts of the blower and its driving equipment can cause serious physical injuries.
- Keep clear of open inlet piping and the discharge of blowers. Before operating the machine with piping disconnected, fit a substantial coarse screen over the open connection.
- Keep clear of the blast from pressure relief valves and unloading valves.
- Keep clear of air blast from discharge of vacuum packages.
- Avoid extended exposure to machinery that exceeds safe noise levels. See Note 1.

Note 1 - To prevent unwanted heat and noise emitting from the customer supplied discharge piping it may be necessary to lag or insulate the customer supplied piping.

DO NOT

- Do not attempt to adjust the setting of the pressure relief valve or unloading valve.
- Do not use gasoline or other flammable fluids to clean blower parts.
- Do not exceed the operating limitations specified in the Contract Details without consulting Dresser Roots.
- Do not operate the unit in an explosive atmosphere or hazardous locations.
- Do not install the machine close to walls or sources of heat.
- Do not bypass or render inoperative any safety or protection devices.
- Do not pressurize vented blower cavities from an external source, nor restrict the vents. The blower casing pressure must not exceed 25 psi (172kPa) gauge.

Other potential safety hazards may also be associated with operation of this machine. All personnel passing through the hazardous area should be warned by signs and trained to exercise adequate precautions.

LONG TERM STORAGE

Package Preservation

The package has been treated internally to protect the components against atmospheric corrosion. The period of internal protection is considered to be one year under average conditions for a package that is stored indoors and the protective packaging material has not been disturbed. Protection against chemical or salt water atmosphere is not provided. Once the protective covering is removed, the corrosion protection will be quickly lost due to evaporation of the preservatives.

If the packaging is disturbed for any reason, or if the protection is required beyond one year, use following procedure to refurbish protection:

- Coat internals of blower cylinder, gearbox and drive end bearing reservoir and require. Nox-Rust VCI-10 Oil or equal. Repeat once a year or as conditions removed before lubricating. For product information and MSDS sheets, go to Web site – www.daubertchemical.com.
- Attach Zerust capsules to the blower base. For product information and MSDS sheets, go to Web site – www.zerust.com.
- Seal the entire package with layers of plastic sheeting or plastic bag. It is very important to make sure that the internal preservative will not escape through any cracks or openings.
- Protect unit from excessive vibration during storage.

Owner Responsibility

Discussion regarding documentation and maintenance to be performed by owner.

To ensure satisfactory operation and protect the integrity of the warranty the below items are the responsibility of the owner and must be performed.

- Customer to record start-up date of each blower package. This will verify the beginning of the operational warranty.
- Gearbox and Drive End lubrication (oil) should be the specified and recommend Roots synthetic lubrication of the proper viscosity for the ambient temperature ranges experienced at the installed location.
- The first lubrication service is to be performed after the first 100 hours of operation. The lubrication must be serviced there after based on the calculation provided in the lubrication section of the blower manual supplied with the package/s.
- Records of service including date and hours since last service must kept and available upon Roots request. Personnel clock number or ID # should be included in the record.
- Drive End lubrication if grease lubricated should be the specified and recommend Shell Darina SD 2 NLGI #2 product code 506762B grease. The grease should be serviced as per the lubrication section of the blower manual supplied with the package/s.
- Belt tension, belt condition and drive component condition must be verified semi monthly. Belt tension must be verified as per the drive belt section of this manual.
- Records of the drive service including date and hours since last service must kept and available upon Roots request.
- The inlet filter must be monitored and serviced as required in order to prevent operating the unit with a restricted inlet.
- Records of the inlet filter service including date and hours since last service must kept and available upon Roots request.
- The drive motor must be maintained as per the motor manufactures instructions provided in the package manual supplied separate of the package.

It is a good practice to record of all gauge readings daily.

Table 1 - Maximum Allowable Operating Conditions & Oil Sump Capacities

| EAX2 Package Size | Blower Size | RPM | Temperature Rise | | Pressure Rise | | Inlet Vacuum | | Oil Sump Capacity | |
|-------------------|-------------|------|------------------|-----|---------------|------|--------------|------|-------------------|--------|
| | | | °F | °C | PSI | mbar | IN HG | mbar | Fluid Ounce | Liters |
| 50 | 22 U-RAI | 5275 | 225 | 125 | 12 | 827 | 15 | 500 | 11 | 0.3 |
| | 32 U-RAI | 3600 | 240 | 133 | 15 | 1034 | 16 | 539 | 33 | 1 |
| | 33 U-RAI | 3600 | 225 | 125 | 12 | 827 | 15 | 500 | 33 | 1 |
| | 42 U-RAI | 3600 | 240 | 133 | 15 | 1034 | 16 | 539 | 39 | 1.2 |
| 65 | 36 U-RAI | 3600 | 225 | 125 | 7 | 483 | 15 | 500 | 33 | 1 |
| | 45 U-RAI | 3600 | 225 | 125 | 10 | 690 | 16 | 539 | 39 | 1.2 |
| | 53 U-RAI | 2850 | 225 | 125 | 15 | 1034 | 16 | 539 | 52 | 1.6 |
| 100 | 47 U-RAI | 3600 | 225 | 125 | 7 | 483 | 15 | 500 | 39 | 1.2 |
| | 56 U-RAI | 2850 | 225 | 125 | 13 | 896 | 16 | 539 | 52 | 1.6 |
| | 59 U-RAI | 2850 | 225 | 125 | 7 | 483 | 15 | 500 | 52 | 1.6 |
| | 404 RAM -J | 4000 | 240 | 133 | 15 | 1034 | 15 | 500 | 67 | 2 |
| | 406 RAM -J | 4000 | 240 | 133 | 15 | 1034 | 15 | 500 | 67 | 2 |
| | 409 RAM -J | 4000 | 240 | 133 | 15 | 1034 | 15 | 500 | 67 | 2 |
| 150 | 155 RAM X | 4750 | 240 | 133 | 15 | 1034 | 16 | 539 | 67 | 2 |
| | 225 RAM X | 4750 | 240 | 133 | 15 | 1034 | 16 | 539 | 67 | 2 |
| | 280 RAM X | 4750 | 230 | 128 | 12 | 827 | 16 | 539 | 67 | 2 |
| 200 | 400 RAM X | 3560 | 230 | 128 | 15 | 1034 | 16 | 539 | 157 | 4.6 |
| | 500 RAM X | 3560 | 230 | 128 | 12 | 827 | 16 | 539 | 157 | 4.6 |
| 250 | 600 RAM X | 3050 | 230 | 128 | 15 | 1034 | 16 | 539 | 237 | 7 |
| | 770 RAM X | 3050 | 230 | 128 | 12 | 827 | 16 | 539 | 237 | 7 |
| 300 | 800 RAM X | 2670 | 230 | 128 | 15 | 1034 | 16 | 539 | 390 | 11.6 |
| | 1000 RAM X | 2670 | 230 | 128 | 12 | 827 | 16 | 539 | 390 | 11.6 |

Description

GENERAL CONFIGURATION

ROOTS™ EasyAir® X2 blower/exhauster packages are available in a range of sizes, with a general configuration as shown. Each unit consists of an acoustic enclosure containing the blower, blower drive, and accessories mounted on a sub-base assembly.

The acoustic enclosure incorporates removable panels for maintenance access, and is fan-ventilated. Anti-vibration mountings support the sub-base assembly, so that no external anti-vibration measures are required.

The motor drives the blower by means of a V-belt equipped with a unique Roots automatic tensioner.

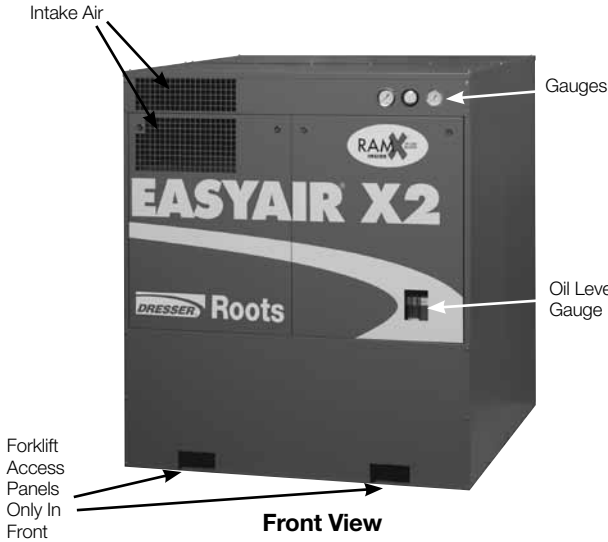

Front View

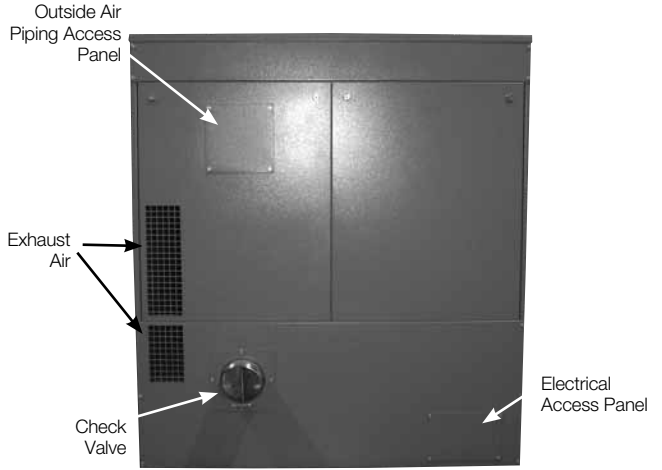

Rear View

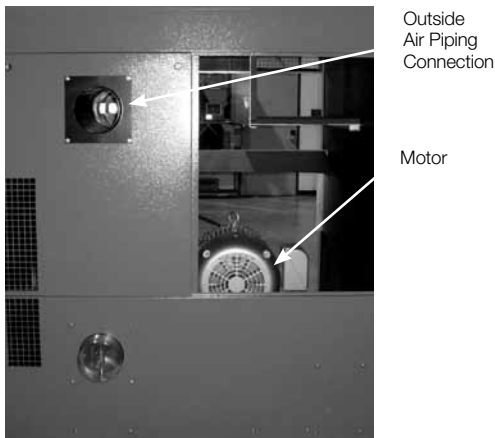

Rear Panels Partially Removed

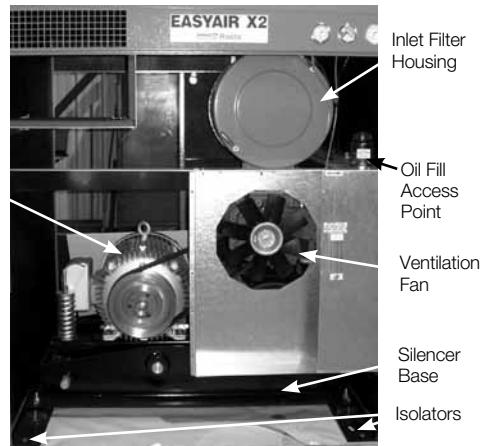

Front Panels Removed

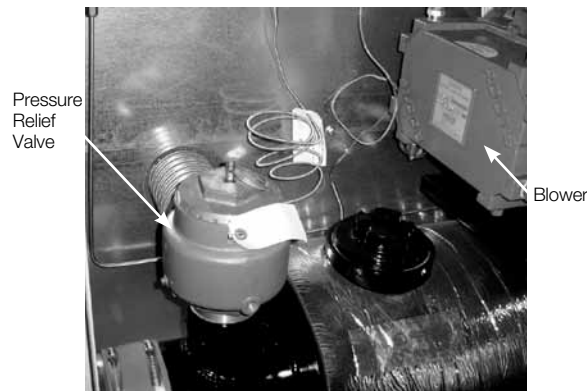

Pressure Relief Valve

Protection Devices and Accessories

STANDARD DEVICES

The following devices are supplied with a standard factory blower package system:

- Inlet filter/silencer
- Panel-mounted filter restriction indicator
- Discharge silencer/sub-base assembly
- Pressure relief valve
- Check valve
- Anti-vibration mounts
- Discharge pressure gauge
- Discharge flex connector (before check valve)
- Oil drain manifold
- Drive motor
- V-belt drive with tension control
- Acoustic enclosure (fan ventilated)
- Discharge Temperature Gauge

OPTIONS

These devices can be supplied on request:

- Switches, pressure and temperature
- Unloading valve
- Lever-operated butterfly isolation valve, mounted in customer piping down stream
- Starter panel
- IntelliView PLC
- Variable speed drive

Installation and Start-Up



LEFT DOOR RIGHT DOOR

CAUTION: LEFT DOOR HAS A LIP AT THE BOTTOM OF THE PANEL ON WHICH THE RIGHT DOOR RESTS, SO THE RIGHT DOOR IS REMOVED FIRST.



DOOR LATCH



EAX2 DOOR REMOVAL PROCEDURE



(1) INSERT THE KEY IN THE LEFT KEY HOLE OF THE DOOR PANEL.



(2) PUSH AND TURN THE KEY ¼ TURN CLOCKWISE, PULL THE DOOR OPEN.



(3) HOLD THE DOOR OPEN, PUSH AND TURN THE KEY ¼ TURN COUNTER CLOCKWISE AND REMOVE THE KEY.



(4) HOLD THE DOOR OPEN WITH LEFT HAND, INSERT KEY IN THE RIGH HOLE, PUSH AND TURN THE KEY ¼ TURN COUNTER CLOCKWISE, PULL THE DOOR OPEN.



(5) HOLD THE DOOR, PUSH AND TURN THE KEY ¼ TURN CLOCKWISE AND REMOVE THE KEY. LIFT UP AND REMOVE THE RIGHT SIDE DOOR PANEL.



(6) FOR REMOVAL OF THE LEFT DOOR PANEL, USE THE PROCEDURE PER (2 & 3) ABOVE TO UNLOCK THE LEFT LATCH, AND (4 & 5) TO UNLOCK THE RIGHT LATCH.

DOOR REMOVAL/INSTALLATION PROCEDURE



(1) LEFT DOOR PANEL IS INSTALLED FIRST. HOLD THE DOOR AWAY FROM THE MATING SURFACE TO PREVENT DAMAGE TO THE PAINT, PUSH AND TURN THE KEY ¼ TURN CLOCKWISE.



(2) PUSH THE DOOR AGAINST THE ENCLOSURE, TURN THE KEY ¼ TURN COUNTER CLOCKWISE AND REMOVE THE KEY.



(3) PULL THE RIGHT SIDE OF THE DOOR PANEL AWAY FROM THE SEATING SURFACE TO PREVENT PAINT DAMAGE,



(4) INSERT KEY AND TURN IT ¼ TURN COUNTER CLOCKWISE.

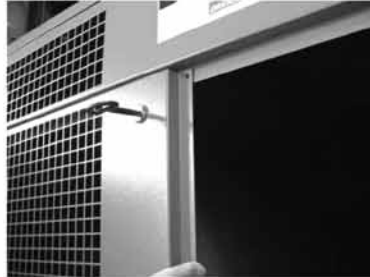

(5) PUSH THE DOOR CLOSE, TURN THE KEY ¼ TURN CLOCKWISE AND REMOVE THE KEY.



(10) FOR INSTALLING RIGHT DOOR PANEL, USE STEPS (3 THRU 5) TO LOCK THE RIGHT LATCH AND STEPS (1 & 2) TO LOCK THE LEFT LATCH.

LOCATION REQUIREMENTS

Select a location away from walls and obstructions. The front and rear panels are removable, but not the side panels. Allow space for access to the front and rear of the machine as shown. Multiple units can be positioned end-to-end with sufficient gap between them to allow free passage. Do not stack vertically.

If side panel access is expected, use 24" access spacing in place of 1".

FOUNDATION

The unit must be mounted on a firm foundation which must be smooth, flat, and level, within .06" in each direction from end to end.

LIFTING AND MOVING

Units are shipped fully assembled.

If weatherhoods are provided, they must be installed once the package is in its final position. Before attempting to lift or move a unit, refer to the table on the right for the unit weight and check that this does not exceed the safe working load of the lifting equipment available and skill level of personnel.

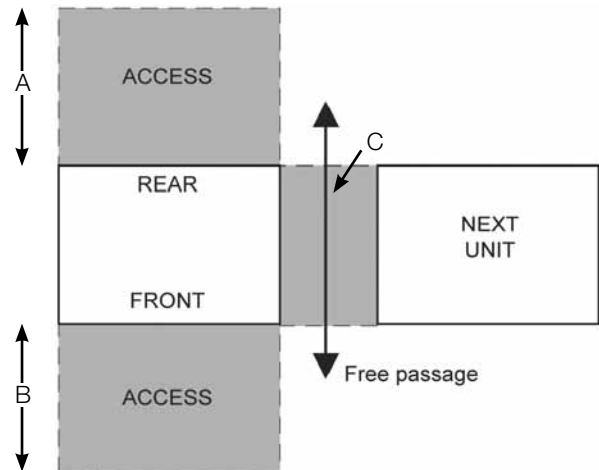

| Pkg Size | A | B | C |
|-----------------------|-----|-----|-----|
| EAX2 50, 65, 100, 150 | 36" | 36" | 1" |
| EAX2 200 | 36" | 36" | 1" |
| EAX2 250, 300 | 36" | 36" | 36" |

| Package Size | Approx. Wgt. (lbs) | Approx. Wgt. (kg) |
|--------------|--------------------|-------------------|
| EAX2 50 | 985 | 448 |
| EAX2 65 | 1230 | 559 |
| EAX2 100 | 2200 | 1000 |
| EAX2 150 | 3600 | 1636 |
| EAX2 200 | 4850 | 2204 |
| EAX2 250 | 7300 | 3318 |
| EAX2 300 | 10400 | 4727 |



Lifting with Fork Lift

LIFTING FULLY-ASSEMBLED UNITS

Remove (4) corner nuts from holding bolts underneath the skid to dislodge enclosure from the skid.

Remove hex head screws securing two cover plates as shown on page 3. Make sure the base is well supported under the entire width by the forks. Lift and move by fork lift.

Anchoring

Bolt down the base frame using (4) 5/8" dia. (19 mm) anchor bolts in the bolt-down holes.

Do not fit external anti-vibration mountings; the machine has integral anti-vibration mountings.

Note: Once the base frame is anchored to the slab, a continuous bead of silicon, except two inches at each corner, should be applied between the cabinet panels and the slab to prevent noise from escaping. Leave adequate path for water drainage.

Electrical



WARNING

Connection and wiring must be carried out by a qualified and authorized person in accordance with local wiring regulations.

Refer to the supplied manufacturer electrical drawings for the main motor and accessories connections.

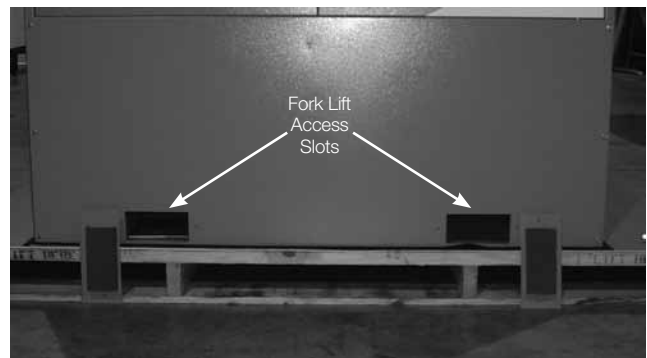

NOTICE

The shipping stud securing the cabinet to the blower/motor base must have the nut #1 removed and nut #2 loosened once the blower is placed into its final position and secured to the foundation.

Nut # 2 should be run down and secured against the lower nut on the stud.

In the event the package is to be relocated in the future the nuts must be replaced before lifting the package.

See the illustration below for clarification.

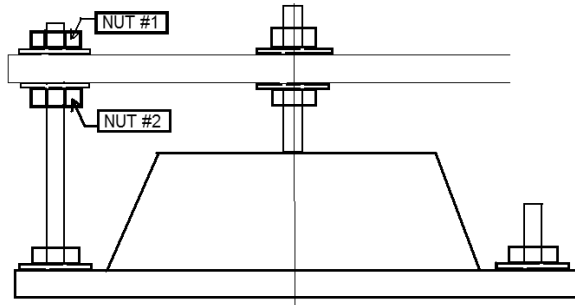

Start-up

| Step | Check/Procedure | Done |
|------|--|--------------------------|
| 1 | Base frame assembly securely anchored to the foundation. See foundation requirements under the "Installation & Start-Up" section of the appropriate blower package manual. | <input type="checkbox"/> |
| 2 | Machine filled with the specified and recommended Roots synthetic lubrication of the proper viscosity for the ambient temperature of the space the blower and motor are located. Detailed instructions regarding filling the blower with lubrication and installing the decal attached to the lubrication sight tube are provided in this manual. Please refer to these instructions for proper filling and decal installation instructions. DO NOT OVERFILL | <input type="checkbox"/> |
| 3 | Piping and check valve connected w/ flexible connection installed. Flexible connections w/ control rods require proper adjustment. Please refer to the appropriate blower package manual for installation procedures. | <input type="checkbox"/> |
| 4 | Drive belt alignment and tension are correct. See "Drive belt" section of the appropriate blower package manual. | <input type="checkbox"/> |
| 5 | Correct direction of rotation is CCW when facing the shaft end of the blower. (Jog motor – check direction corresponds with direction shown by the direction arrows) Wait for the blower to come to complete stop before restarting (jogging) the motor. | <input type="checkbox"/> |
| 6 | Run machine for 1-1/2 hours. Check for leaks, vibration, hot spots or unusual noises. | <input type="checkbox"/> |
| 7 | Re-check drive belt tension to verify correct after first 8 hours of operation. | <input type="checkbox"/> |
| 8 | Verify relief valve operation. | <input type="checkbox"/> |
| 9 | If the package has shut down/alarm instrumentation verify if shut down/alarm instrumentation is installed and operating. | <input type="checkbox"/> |
| 10 | Refer to the "filter" comments under "Maintenance & Lubrication" section and mark the filter indicator gage accordingly. | <input type="checkbox"/> |
| 11 | If the package was supplied with a 0" to 60" H2O filter indicator gauge refer to the "filter" comments under "Maintenance & Lubrication" section and mark the filter indicator gage accordingly. | <input type="checkbox"/> |
| 12 | For EAX2™ verify a bead of silicone has been applied around the outside perimeter of the enclosure to the concrete foundation. | <input type="checkbox"/> |
| 13 | Drive motor properly greased. Follow detailed instructions provided. | <input type="checkbox"/> |

Check Valve Installation

The screws protruding through the top and the bottom of the valve body must be in the vertical position.



Piping Configuration

To prevent unwanted heat and noise emitting from the customer supplied discharge piping, it may be necessary to lag or insulate the customer supplied piping.

Customer Piping Connection: Customer piping discharge/inlet should be connected to the package in a manner that will not exert external forces on the package. A flexible expansion joint should be used between package and the customer connection.

INSTALLATION OF CONTROL RODS FOR METAL BELLOWS TYPE EXPANSION JOINTS:

Tighten nut "B" against the control rod lug.

To prevent over extension of the bellows, nuts "A" and "E" are welded to the control rods.

To prevent over compression of the bellows, locate nut "D" 0.50" from the lug "F". Jam nut "C" against nut "D" to prevent its movement during operation.

There are four control rods "E" per expansion joint.

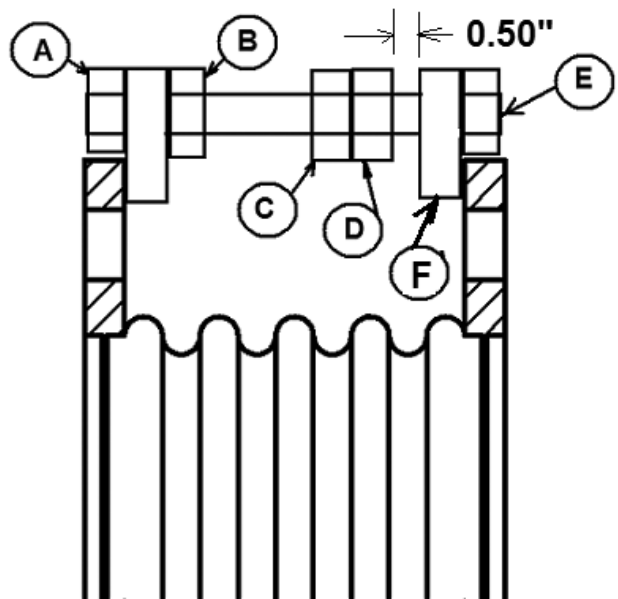

Maintenance and Lubrication

Access



CAUTION

If machine is observed while in operation, all relevant Health and Safety Steps and Precautions must be adhered to!



Hearing protection must be worn for running visual inspection!

Routine Maintenance Schedule

| Frequency | Item | Action | Reference |
|-------------|-------------|---|--------------------|
| Weekly | Filter | Refer to the filter section for pressure units and the vacuum section for vacuum unit inlet filter service intervals. | Filter, page 13 |
| | Drive | Check condition of belts. | Drive belt, pg. 15 |
| Monthly | Lubrication | Check lubricant level and top off if necessary. | See blower manual |
| | Drive | Verify belt tension as per the "Drive Belt" section of this manual. | Drive belt, pg. 15 |
| As required | Lubrication | Refer to section "How to properly determine the oil service intervals". | See pg. 12 |
| | Ventilation | Check condition and operation of ventilation fan. Clean fan. | |

*More frequent check/change may be required depending on operating lubrication temperature. Refer to blower manual.

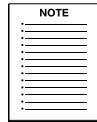

For maintenance of the motor, refer to the manufacturer's manual.

Due to sludge build-up and seal leakage problems, Roots recommendation is DO NOT USE Mobil SHC synthetic lubricants in ROOTS™ blowers.

During the initial start-up the below instructions must be followed.

Lubrication Decal installation procedure.

Please follow the below steps before installing the supplied lubrication decal(s).

- Using the table below select the appropriate blower frame size supplied in the package. The blower frame size can be found on the serial tag located on the gearbox or opposite end of the drive on the blower itself.

These capacities above are provided to assist with the lubrication filling process of EAX2 packages. Exact sump capacity may differ slightly depending somewhat on the level of the package.

See Table 1 for approximate oil sump capacities.

Note: the blower/silencer base must be level with in 1/16" each direction.

- Using the lubrication sump capacities provided above measure the called out amount of the specified and recommended Roots synthetic lubrication and pour these amounts into each respective drive end and gear end lubrication sump.
- Allow sufficient time for the lubrication to level out in the lubrication sumps.

- Allow sufficient time for the lubrication to make its way through the hoses and into the lubrication sight tube mounted on the front of the cabinet.
- After a period of time verify the lubrication level in the two sight glasses on the blower itself. The lubrication level in the sight glasses on the blower should be within .060" of the center line of the sight glasses. The two sight glasses are located on the left side (motor side) of the blower when facing the drive end of the blower.
- Adjust each lubrication sump until the lubrication level in both sight glasses on the blower is within .060" of the center line of the sight glasses. DO NOT OVERFILL.
- After sufficient time has transpired for the lubrication to make its way through the hoses and into the lubrication sight tube mounted on the front of the cabinet note the lubrication level in the sight tube.
- Remove the decal backing exposing the self adhesive surface and apply it to the lubrication sight tube with the bottom of the top red line at the top of the lubrication level in the sight tube.
- The lubrication level must be maintained between the two red lines on the decal when the blower is not operating.



WARNING

Top off the lubrication when the machine is stopped; never while it is running.

The lubrication level should be between the indicator lines when the unit is not operating as shown below.

To top off, remove fill bottle cap, add lubricant until the level is correct, and close the filler cap. Do not over-fill.

Draining and Filling

To drain the lubricant:

1. Stop the machine and disconnect the power supply.
2. Remove the upper door panel from the front of the enclosure.
3. Place a suitable container beneath the drain in front of level gauge.
4. Remove breathers from blower covers and loosen and remove drain plug in front of oil level gauge.

To refill:

1. Close and tighten the drain plug.
2. Add lubrication through the breather holes in blower covers until the level is between the lines marked on the decal. Again, the unit must be filled when the unit is not operating. Never over-fill. Lubricant could be filled thru fill bottle, but this will take relatively longer time.
3. Replace the breathers.
5. Clean up any spilled lubrication for safety.
6. Replace the door on the enclosure.

How to properly determine the oil service intervals.

The first lubrication service is to be performed after the first 100 hours of operation.

Normal life expectancy of the specified and recommended ROOTS® Synthetic oil is approximately 6000 hours with an oil temperature of 180°F (82°C) or less. As the oil temperature increases by increments of 15°F (8°C), the oil life is reduced by half for each 15°F (8°C) increase. Example: Oil temperatures of 195°F (90.5°C) will produce a life expectancy reduced by half or 3000 hours oil service life.

NOTE: To estimate oil temperature, multiply the discharge temperature of the blower by 0.88. Example: if the discharge air temperature of the blower is 200° F, it is estimated that the oil temperature is 160° F

High ambient temperatures contribute to increased lubrication sump temperatures. In situations such as blowers in an enclosure, blowers exposed to radiant heat from other sources, blowers installed in areas with poor circulation or ambient temperatures above 80°F the lubrication sump temperature should be measured rather than fully rely on the calculation.



CAUTION

The machine is delivered without lubrication. Before proceeding, fill the blower with lubrication of the correct type as detailed in the blower IOM manual. Lubricate motor per manufacturer recommendation.

The specified and recommended lubrication is ROOTS® Synthetic Lubrication P/N 813-106-XXX of the proper viscosity for the ambient temperature of the space blower and motor are mounted in.

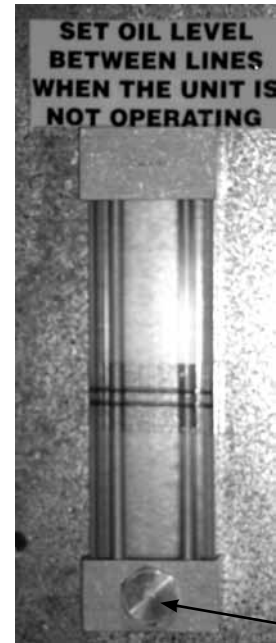

LUBRICANT DRAIN PLUG

ENCLOSURE TEMPERATURE

Packages are generally supplied with 40°C standard motors. In this case, the temperature inside the enclosure must not exceed 120°F (49°C).

For very hot climates, 50°C motors are required, in this case, the temperature inside the enclosure must not exceed 135°F (57°C). More frequent lubrication service intervals will be required for higher enclosure temperatures.

Start-Up

Carry out the following checks and procedures, and check the boxes to verify that the start-up has been carried out correctly:

Table of Recommended Oil Grades

| Ambient* Temperature °F (°C) | ISO Viscosity No. |
|------------------------------|-------------------|
| Above 90° (32°) | 320 |
| 32° to 90° (0° to 32°) | 220 |
| 0° to 32° (-18° to 0°) | 150 |
| Below 0° (-18°) | 100 |

*Ambient temperature is defined as the temperature of the space in which the blower and drive are located.

Filter

At start-up of the package and under normal loaded conditions note the base reading vacuum level on the filter gauge with the clean new filter element installed. The filter must be renewed at 10" -15" (254-381mm) H₂O above the base reading.

It is recommended that the filter indicator gauge be marked at 10" (254mm) H₂O and 15" (381mm) H₂O above the base reading. The filter element must be renewed when the reading is between these two marks.

Allowing the package to operate with a restricted inlet filter results in overheating, possible damage to the blower lubricant and wasted power.

For the packages supplied with color coded filter gauge, if the indicator is in green zone, no action is required. If the indicator is in the yellow zone, schedule service to replace the filter. If the indicator is in the red zone, replace the filter.

Replacing the Filter

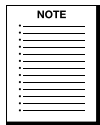

We recommend that you keep two or more spare filter elements and replace them as indicted in the Routine Maintenance Schedule. See below.

When replacing always use genuine Dresser parts.

Changing the Filter



CAUTION

Machine must be switched off, fully isolated and stationary before attempting to clean or change the filter element!

- Remove filter lid depending on type. (See pictures this page).
- Break seal and lift lid off.
- Remove filter element.
- Inspect.
- Refit or replace element.
- Refit lid and fasten in position.

Filter Gauge



Dwyer Gauge



FILTER REMOVAL

Figure A: Loosen four handles and remove the cover.

Figure B: Slide out the filter and plate assembly.

Figure C: Remove the filter plate.

FILTER INSTALLATION

Figure D: Slide the filter in and make sure it seats properly on the bottom.

Figure E: Install filter plate making sure that the plate pin lines up with the top hole in the filter support bracket.

Figure F: Install filter plate making sure that the plate pins line up with the filter flange holes. Tighten handles securely.

Figure A



Figure B



Figure C



Figure D



Cover pin goes in this top hole.

Figure E



Figure F



This alignment pin goes into the hole in this flange

Drive Belt



CAUTION

When rotating pulleys by hand, beware of finger entrapment between belt(s) and pulleys!

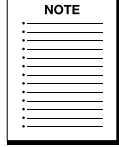

Always ensure when replacing any parts of the drive that identical replacements are always used. The use of non compatible replacements can result in severe damage of the machine!

Single Barrel Tension Indicator



Double Barrel Tension Tester



Five Barrel Tension Tester



The automatic tensioner maintains the correct V-belt tension under normal working conditions, but it is good practice to check that the tensioner is performing correctly as indicated in the Routine Maintenance Schedule (page 10).

Note: The proper belt tension should be obtained from the files provided with the blower package or by contacting Dresser Roots.

Belts with more than 24 hours of service are considered “used”.

Note: Drives supplied by Dresser Roots on EAX2 packages with three or more belts generally have banded belts.

Generally the deflection force and distance provided either in the file or by Dresser Roots is for a single belt/strand. Banded belt deflection force can be obtained by multiplying the number of bands/strands of a multi-banded belt by the installation deflection force of a single band/strand.

The installation deflection distance does not change with the number of bands.

In the event the deflection force exceeds 35 lbs. it will be necessary to use either a multi-barrel tension tester or you may choose to contact Dresser Roots for other possible methods and tools.



CAUTION

Drive alignment is factory set but may move during transportation, it is therefore good practice to check the drive alignment on initial installation!

Occasions when the following procedures will be required are when either the motor or blower has been fully removed for overhaul!

In the event of the drive needing realignment use the following procedure:

- Secure Blower in position.
- Leave motor bolts finger tight.
- Ensure there is NO tension applied by the self-tensioner (fully released).
- Using a straight edge pushed hard against the blower pulley face with right hand. Allow the left hand to drop down towards the motor pulley. Check position of motor pulley face against straight edge.
- Reposition motor as necessary to ensure straight alignment of both pulleys.
- Carefully re-tighten motor bolts fully and re check alignment.
- Refit belt(s).
- Spin the pulleys 3 to 4 revolutions to bed belts into the pulley grooves.
- Tension belts per manufacturer recommendations.



Procedure describing the removal and replacement of drive belts.

Removal:

- On top of the tension spring and on the threaded rod is two nuts locked together. Using two wrenches break the two nuts loose.
- Loosen the top nut approximately two inches. Then loosen the second nut and this will begin to loosen the tension on the spring and allow the belt tension to be released.
- The nuts must be loosened enough to allow the belts to be removed without having to force the belts over the rim of the pulleys. Remove the belts.

Replacement:



(1) Remove the front two panels by unscrewing M6 screws. This will expose the fan and the motor sheave.

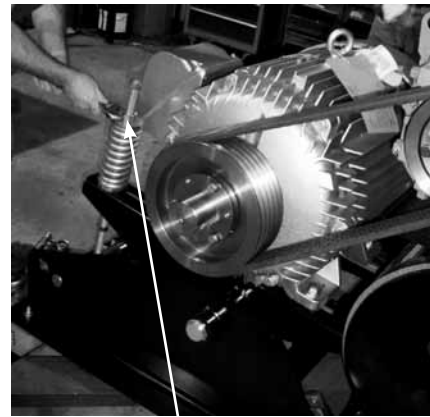
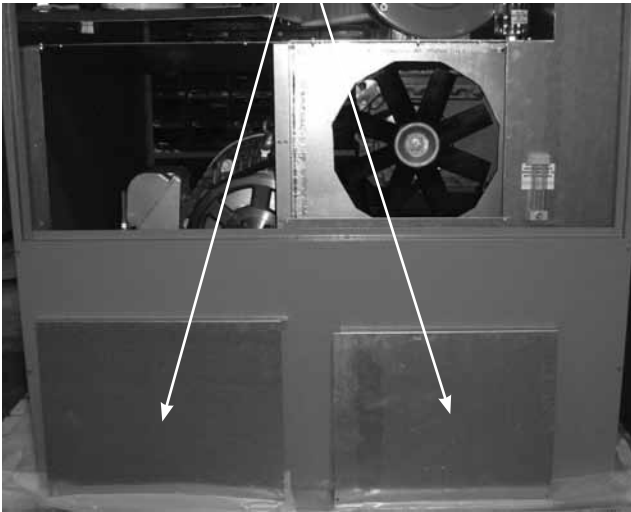

(2) Loosen up the spring nuts and move both of them up to the end of the rod. This will free up the spring.



(3) Raise the to nut all the way up to the motor pad. Continue to raise the nut. This will cause the motor to tilt forward releasing the belt tension.



Loosened belts



(4) Lift the belt out of the sheave grooves.



(5) Pass the belt between the sheave and the exhaust plenum.



(6) Pull the belt out through the clearance between the fan OD and the panel hole.

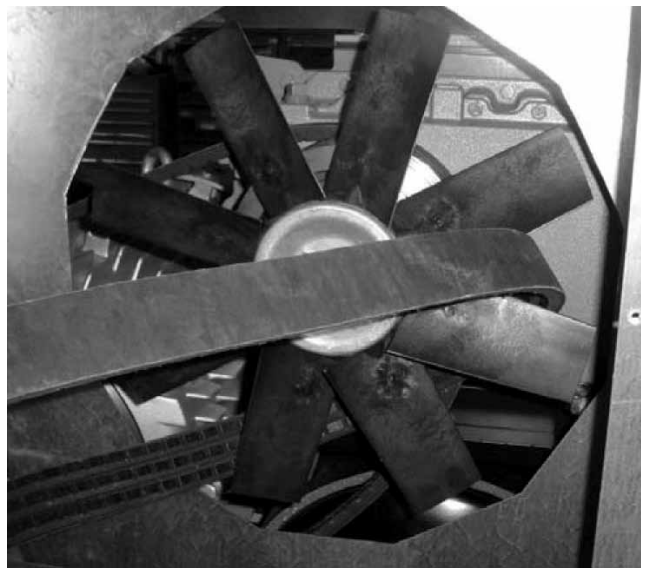

Continuation of step 6

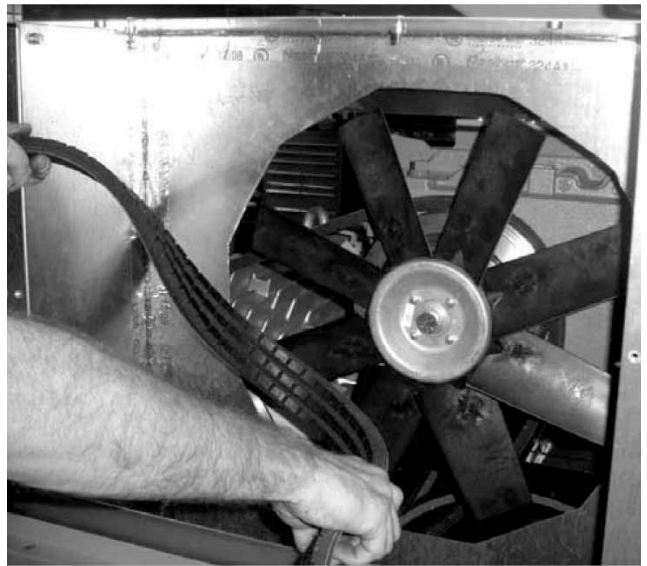

CAUTION: In some cases it may be necessary to remove the fan for belt replacement.

Belt Installation



(1) Pass the belt through the clearance between the panel hole and the blade OD and on to the sheave grooves.



(2) Slide the belts into the pulley grooves of the motor and the blower.

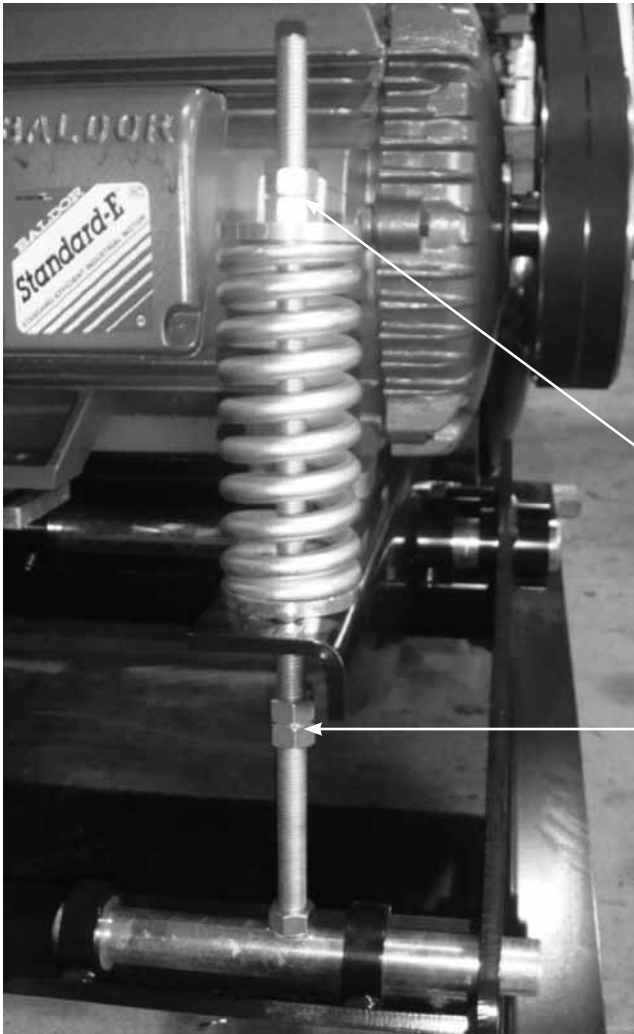

(3) Lower the nuts (A) away from the motor pad. Lower the the nuts (B) against the spring washer and apply slight compression. Spin the pulleys 3 to 4 revolutions to bed the belts into the pulley grooves. Adjust the belt tension by moving two spring nuts (B) up or down as required. Once proper tension is achieved, tightne the top nut against the bottom nut to prevent it from loosening up during operation. Set nuts (A) about an inch below the motor pad and jam them against each other. In case of belt breakage, these nuts will prevent motor from falling further.

Set V-belt tension per drive manufacturer recommendation using pencil or sonic tension tester.

(B)

(A)



(4) Verify belt tension after the blower has operated for period of 24 hours.

Dodge belt tension tester Part # 109082

Instruction is availabel from Dodge Web site,
http://www.dodgept.com/pdf/instruct_manuals/pt_components/vdrives_sprocket_chain/499515.pdf

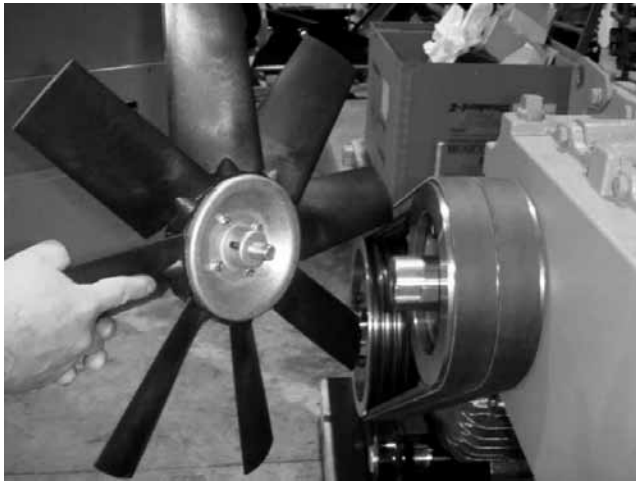

If it becomes necessary to remove the fan for belt replacement, please follow the instructions below to install the fan.

(1) Clean shaft and bolt threads thoroughly. Both these threads must be 100% oil free. Apply **Loctite 272** to bolt threads. Make sure the fan hub is towards the shaft. Install fan. Torque bolt to the values listed below first and then the set screw in the fan hub

| Blower Size | Fan Bolt Torque (Ft/lb) |
|-------------------|-------------------------|
| RAM X 155/225/280 | 85 |
| RAM X 400/500 | 175 |
| RAM X 600/770 | 175 |
| RAM X 800/1000 | 450 |

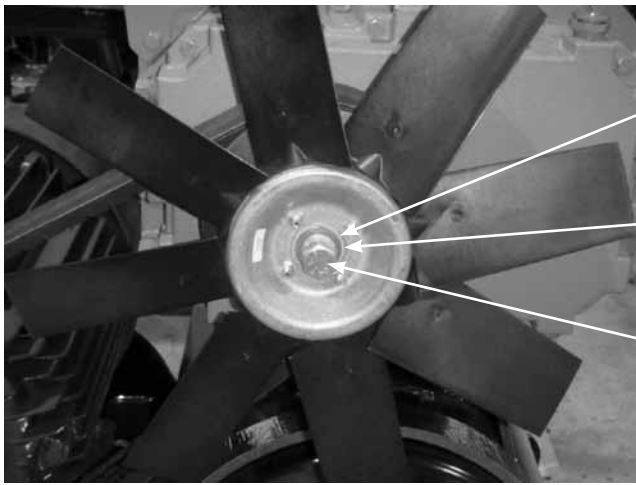

Flat washer next to the fan hub

Lock washer under the bolt head

Bolt

NOTE: In some cases, there may be a spacer between the shaft and the fan.

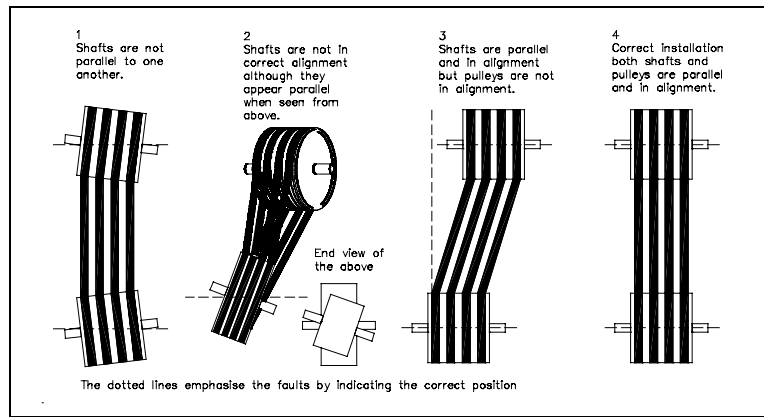

PRESSURE RELIEF VALVE



CAUTION

Never attempt to readjust the valve setting(s). If there is a problem consult with a member of Dresser Roots Aftermarket/Service team.

This machine is fitted with a factory-set pressure relief valve. This device is to prevent over pressurizing of the blower, silencer and other parts of the system.

The valve will open whenever the system pressure reaches the relief valve setting; this is an indication that there is something wrong in the downstream pipe work.

If the valve opens, shut down the system immediately and determine the cause of obstruction in the discharge pipe work. Do not simply try to stop this by readjusting the valve settings.

Possible causes: closed isolation valve, build up of material in the system pipe work or some other type of obstruction.

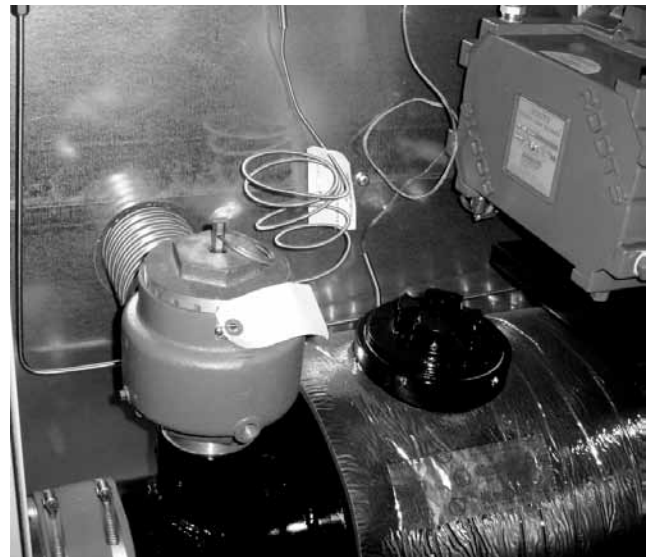

Pressure Relief Valve



CAUTION

Do not operate blower for extended period with relief valve open, this will cause the enclosure temperature to rise suddenly and may damage the equipment inside.

Vacuum Package Section

Filter

Follow these instructions to determine when the inlet filter element should be serviced. At start-up of the package and under normal loaded conditions note the base reading vacuum level on the filter gauge with the clean new filter element installed. The filter must be cleaned or renewed at 10"-15" H₂O above the base reading. It is recommended that the filter indicator gauge be marked at 10" H₂O and 15" H₂O above the base reading. The filter element must be cleaned or renewed when the reading is between these two marks. Never allow the package to operate with a restricted inlet filter.

Please refer to the Maintenance & Lubrication section of this manual for additional warnings and filter replacement instructions.

Warning

Air blast and noise from discharge of vacuum packages must be treated to prevent injury or excessive noise.

Discharge air from vacuum packages can be piped away from the package. Please consult Roots regarding treating the air blast.

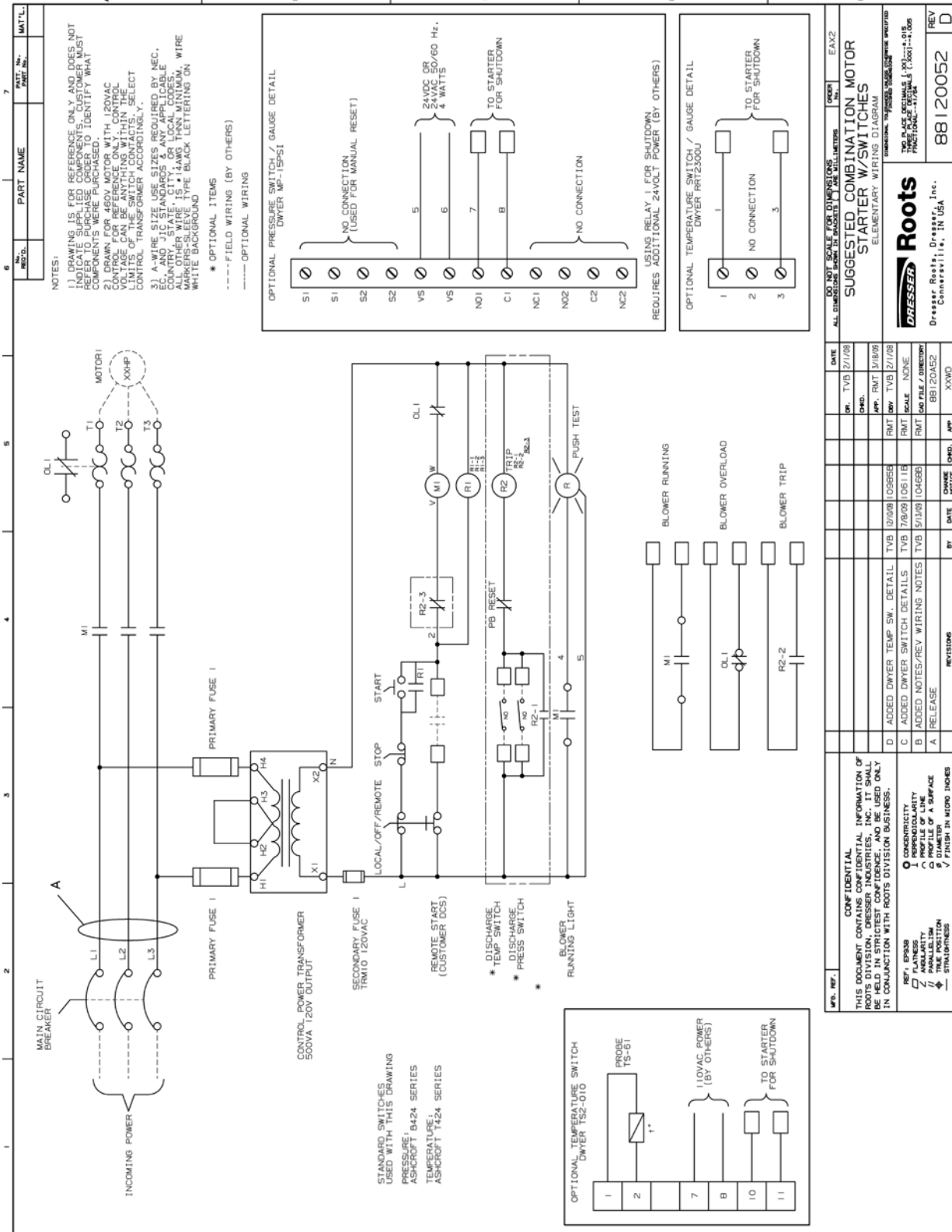

NOTES:
 1.) DRAWING IS FOR REFERENCE ONLY AND DOES NOT INDICATE SUPPLIED COMPONENTS. CUSTOMER MUST CONTACT SUPPLIER TO IDENTIFY WHAT COMPONENTS WERE PURCHASED.
 2.) DRAWN FOR 460V MOTOR WITH 120VAC CONTROL. FOR REFERENCE ONLY. CONTROL LIMITS OF THE SWITCH CONTACTS, SELECT CONTROL TRANSFORMER ACCORDINGLY.
 3.) A-WIRE SIZE USE SIZES REQUIRED BY NEC. CABLE AND JST STANDARDS OR ANY APPROVED EQUIVALENT. ALL OTHER WIRE IS 14AWG THIN MINIMUM. WIRE MUST BE UNCOATED TYPE BLACK LETTERING ON WHITE BACKGROUND.
 * OPTIONAL ITEMS
 ---- FIELD WIRING (BY OTHERS)
 ----- OPTIONAL WIRING

OPTIONAL PRESSURE SWITCH / GAUGE DETAIL
 DWYER WP-15PS1
 NO CONNECTION (USED FOR MANUAL RESET)
 24VDC OR 60 Hz, 4 WATTS
 TO STARTER FOR SHUTDOWN
 NO CONNECTION
 USING RELAY 1 FOR SHUTDOWN
 REQUIRES ADDITIONAL 24VOLT POWER (BY OTHERS)

OPTIONAL TEMPERATURE SWITCH / GAUGE DETAIL
 DWYER PRT2300U
 NO CONNECTION
 TO STARTER FOR SHUTDOWN

| DATE | BY | CHKD. | APP. | DATE | BY | CHKD. | APP. |
|----------|-----------------|-------|------|----------|-----|-------|------|
| 12/17/08 | TVB | | | 12/17/08 | TVB | | |
| 1/16/09 | RMT | | | 2/7/09 | RMT | | |
| 12/17/08 | RMT | | | 09/25/08 | TVB | | |
| 12/17/08 | RMT | | | 06/11/08 | RMT | | |
| | SCALE | | | NONE | | | |
| | REV | | | 04/26/08 | TVB | | |
| | FILE / DIRECTOR | | | 04/26/08 | TVB | | |
| | REV | | | 04/26/08 | TVB | | |
| | DATE | | | 04/26/08 | TVB | | |
| | BY | | | 04/26/08 | TVB | | |
| | NOTICE | | | 04/26/08 | TVB | | |
| | REVISIONS | | | 04/26/08 | TVB | | |
| | DATE | | | 04/26/08 | TVB | | |
| | BY | | | 04/26/08 | TVB | | |
| | CHKD. | | | 04/26/08 | TVB | | |
| | APP. | | | 04/26/08 | TVB | | |
| | DATE | | | 04/26/08 | TVB | | |
| | BY | | | 04/26/08 | TVB | | |
| | CHKD. | | | 04/26/08 | TVB | | |
| | APP. | | | 04/26/08 | TVB | | |
| | DATE | | | 04/26/08 | TVB | | |
| | BY | | | 04/26/08 | TVB | | |
| | CHKD. | | | 04/26/08 | TVB | | |
| | APP. | | | 04/26/08 | TVB | | |

CONFIDENTIAL
 THIS DOCUMENT CONTAINS CONFIDENTIAL INFORMATION OF DRESSER. IT IS TO BE KEPT IN STRICTLY CONFIDENTIAL AND BE USED ONLY IN CONJUNCTION WITH ROOTS DIVISION BUSINESS.
 REF: EPANS
 FLATNESS
 ANGLE
 PROFILE OF LINE
 PROFILE OF SURFACE
 THICKNESS
 DIAL POSITION
 STRAIGHTNESS

DO NOT SCALE FOR DIMENSIONS
 ALL DIMENSIONS SHOWN IN BRACKETS [] ARE IN MILLIMETERS
 ORDER No. EAX2

SUGGESTED COMBINATION MOTOR STARTER W/SWITCHES
 ELEMENTARY WIRING DIAGRAM

Roots
 Dresser Roots Drivetrain, Inc.
 Charlotte, NC, USA

TOP PLACE ORIGINALS (300) 444-0100
 FAX (300) 444-0100
 WWW.ROOTS.COM

REV 88120052 D

About Dresser Roots

Dresser Roots, a major product brand of Dresser, Inc., is the manufacturer of the original ROOTS blower™, centrifugal compressors and control systems. ROOTS® air and gas moving equipment is used in a wide variety of applications, including Mechanical Vapor Recompression, water and wastewater treatment, flue gas desulphurization, petrochemical and chemical processes, conveying, and other industrial applications.

About Dresser, Inc.

Dresser, Inc. is a leader in providing highly engineered infrastructure products for the global energy industry. The company has leading positions in a broad portfolio of products, including valves, actuators, meters, switches, regulators, piping products, natural gas-fueled engines, retail fuel dispensers and associated retail point-of-sale systems, and air and gas handling equipment. Leading brand names within the Dresser portfolio include Dresser Wayne® retail fueling systems, Waukesha® natural gas-fired engines, Masonellan® control valves, Consolidated® pressure relief valves, and Roots® blowers. It has manufacturing and customer service facilities located strategically worldwide and a sales presence in more than 150 countries.

Dresser Roots

Houston, Texas Headquarters • U.S. Toll Free Phone: 1 877-363-ROOT(S) (7668) • Direct Phone: +1 832-590-2600

Connersville, Indiana Operations • Direct Phone: +1 765-827-9200

European Operations • Phone: +44 (0) 1695 52600 • Email: roots.europe@dresser.com

USA/Canada Sales • Phone: +1 773-444-3360

Houston, Texas Factory Service • Phone: +1 713-896-4810

Mexico City Sales and Factory Service • Phone: +52 55 5889 5811

Dubai Sales and Factory Service • Phone: +971 4-8855481

Malaysia Sales • Phone: +60 3 2267 2600

China Sales • Phone: +86 10 8486 2440

Shanghai Factory Service • Phone: +86 21 5858 7638



©2011 Dresser, Inc. All rights reserved. • Printed in the U.S.A. • All information subject to change without notice. • Roots, Wayne, Waukesha, Masonellan, Consolidated and EasyAir are registered trademarks of Dresser, Inc. • ROOTS and WHISPAIR, are trademarks of Dresser, Inc.